

# MINI and MIX Series

## I/O modules

User Manual

**BACnet**



Global Control 5 Sp. z o.o.  
Warsaw, Poland  
[www.gc5.pl](http://www.gc5.pl)

# Table of contents

<b>1</b>	<b>Introduction.....</b>	<b>4</b>
1.1	Revision history .....	4
1.2	Safety rules .....	6
1.3	EN 60730-1 Power supply considerations .....	6
1.4	FCC Compliance note .....	6
1.5	Technical specifications.....	8
1.6	Summary table for all modules.....	10
1.7	Dimensions.....	11
1.8	Power supply connection .....	12
1.9	Connecting the communication bus (RS485) .....	12
1.10	LED Indicators.....	14
1.11	General wiring rules .....	15
1.12	RS485 network termination.....	15
1.13	Setting Module MAC .....	16
1.14	Setting Device ID.....	16
1.15	Baud rate selection.....	16
1.16	Protocol selection.....	17
1.17	Restoring the default settings.....	17
1.18	Default Settings .....	17
<b>2</b>	<b>Conformance statement regarding the implementation of the protocol.....</b>	<b>19</b>
2.1	Conformance Statement regarding BACnet Protocol Implementation .....	19
2.2	BACnet Standardized Device Profile .....	19
2.3	Supported BACnet Interoperability Building Blocks .....	19
2.4	Supported BACnet Standard Object Types.....	20
2.5	Data Link Layer Option .....	20
2.6	Character Sets Supported.....	20
2.7	Supported Application Services .....	21
2.8	About COV .....	21
2.9	Device BACnet Objects.....	22
2.9.1	Device BACnet Object description.....	22
2.9.2	VALID_FRAMES_FOR_US_CNT Property 5101.....	23
2.9.3	VALID_FRAMES_FOR_NOT_US_CNT Property 5102 .....	23
2.9.4	ERROR_FRAMES_CNT Property 5103 .....	23
2.9.5	TRANSMITTED_FRAMES_CNT Property 5104.....	23
2.9.6	UP_TIME Object (Analog Value: 0).....	23
2.9.7	WATCHDOG Object (Analog Value: 1) .....	23
2.9.8	FIRMWARE VERSION AND MODULE TYPE Property 3030 .....	24
2.9.9	RS485_BIASING Property 3045.....	25
<b>3</b>	<b>Local I/O .....</b>	<b>26</b>
3.1	Universal Inputs connections .....	26
3.1.1	Connection of Universal Input to measure voltage 0 – 10 V .....	26
3.1.2	Connection of the Universal Input to measure current 0 – 20 mA.....	26
3.1.3	Connection of Universal Input to measure the temperature.....	27
3.1.4	Connection of Universal Input as a Digital Input (Dry Contact).....	27
3.2	Universal Input BACnet objects .....	28
3.2.1	UI - Universal Input object description (Analog Input: 0 - 7).....	28
3.2.2	UI CONFIGURATION Object (Multistate Value: 1 – 8).....	29
3.2.3	UI RESOLUTION Object (Multistate Value: 9 – 16).....	29
3.2.4	UI FILTER Object (Analog Value: 14 – 21) .....	30
3.2.5	UI DRY_CONTACT Object (Binary Value: 0 – 7).....	30
3.3	Digital Inputs connections .....	31
3.3.1	Connection of Digital Input (Dry Contact) .....	31
3.4	Digital Input BACnet objects .....	31
3.4.1	BI - Digital Input object description (Binary Input: 0 - 11).....	31
3.4.2	BIA COUNTER Object (Accumulator: 0 – 12).....	32
3.4.3	BI COUNTER Object (Analog Value: 2 – 13).....	32
3.5	Analog Outputs connections .....	33
3.5.1	Connection of Analog Output 0 – 10 V.....	33
3.5.2	Connecting relay to the Analog Output .....	33
3.5.3	Connecting an actuator to the Analog Output .....	33

Analog Output BACnet objects .....	34
3.5.4 AO - Analog Output object description (Analog Output: 0 - 5).....	34
3.5.5 AO CONFIGURATION Object (Multistate Value: 17 – 22).....	35
3.5.6 AO HAND_STATUS Object (Multistate Value: 23 – 26).....	35
3.5.7 AO HAND_VALUE Object (Analog Value: 22 – 25) .....	36
3.6 Digital Output relay connections .....	37
3.6.1 Connecting a solenoid valve to the Digital Output .....	37
3.6.2 Connecting a resistive load to the Digital Output .....	37
3.6.3 Connecting an inductive load to the Digital Output .....	37
3.7 Digital Output BACnet objects.....	38
3.7.1 BO - Digital Output object description.....	38
3.7.2 HAND_STATUS Object (Multistate Value: 23 – 26) .....	39
3.8 Triac Outputs (TO) connections .....	40
3.8.1 Connecting a solenoid valve to the Triac Output.....	40
3.8.2 Connecting a resistive load to the Triac Output .....	40
3.9 Triac Outputs (TO) BACnet objects.....	41
3.9.1 TO - Triac Output object description (Binary Output: 0 – 3).....	41
3.9.2 TO PWM VALUE - Triac PWM object description .....	43
(Analog Output: 0 - 3).....	43
3.9.3 HAND_STATUS Object (Multistate Value: 23 – 26).....	44
3.9.4 TO CONFIGURATION Object (Multistate Value: 17 – 22).....	45
3.10 Special application modes for 4I4O-H, 4I4O-H-IP, 4U4O-H, and 4U4O-H-IP .....	45
3.10.1 INPUT MODE Object (Multistate Value: 27 – 30).....	46
3.10.2 MODE TIME Object (Analog Value: 26 – 29).....	49
3.10.3 COMMAND Object (Binary Value: 12 – 15) .....	49
3.10.4 BLOCKING Object (Binary Value: 8 – 11).....	49
3.10.5 SETPOINT Object (Analog Value: 30 – 33) .....	49
3.10.6 DIFFERENTIAL Object (Analog Value: 34 – 37).....	49
<b>5 WEB Configuration - IP version only.....</b>	<b>50</b>
5.1 Web server access.....	50
5.2 Device page .....	50
5.3 Local I/O status and configuration.....	51
5.3.1 Universal Inputs .....	51
5.3.2 Configuration of special application modes .....	52
5.3.3 Digital Inputs .....	53
5.3.4 Digital Outputs .....	54
5.3.5 Analog Outputs .....	54
5.4 RS485 Configuration .....	55
5.5 IP Configuration.....	56
5.6 Device management .....	58
5.7 Contact .....	58
<b>6 BACnet Object Table .....</b>	<b>59</b>
<b>7 List of supported temperature sensors.....</b>	<b>63</b>

# 1 Introduction

## 1.1 Revision history

Rev	Date	Description
1.0	2015.08.28	First edition
1.1	2016.02.01	<p>The reason for the creation of a new version of the document: On 12.2015, GC5 released a new hardware version for MIX module with more a powerful processor and a USB port. For this hardware, and for all MINI series devices, 4.0 firmware was released which contains a bug fixes, firmware improvements and also a rebuilt BACnet protocol (new object, COV).</p> <p>As of 2016, all the modules purchased are equipped with improved versions of the relays, which allow for increasing the capacitive load. <a href="#">Details of the technical specifications.</a></p> <p><b>Note:</b> This document was created for devices with firmware version 4.0 and above. For previous firmware version please read BACnet Manual version 1.0.</p> <p>Changes in Document:</p> <ul style="list-style-type: none"> <li>• Information about the <a href="#">capacitive load relay added to the technical specifications.</a></li> <li>• Information about <a href="#">load Triac Outputs added to the technical specifications.</a></li> <li>• Information about <a href="#">COV added.</a></li> <li>• New BACnet objects: <a href="#">UP_TIME</a> and <a href="#">WATCHDOG.</a></li> <li>• Universal Inputs: <a href="#">COV support and new feature of flag OUT_OF_SERVICE added.</a></li> <li>• Universal Inputs: new objects added: <a href="#">UI_CONFIGURATION, UI_RESOLUTION, UI_FILTER</a> and <a href="#">UI_DRY CONTACT.</a></li> <li>• Digital Inputs: <a href="#">COV support and new feature of flag OUT_OF_SERVICE added.</a></li> <li>• Digital Inputs: new objects added: <a href="#">BIA_COUNTER, and BI_COUNTER.</a></li> <li>• Analog Outputs: <a href="#">COV support and new feature of flags OUT_OF_SERVICE and STATUS_FLAG added.</a></li> <li>• Analog Outputs: new objects added: <a href="#">AO_CONFIGURATION, AO_HAND_STATUS, and AO_HAND_VALUE.</a></li> <li>• Digital Outputs: <a href="#">COV support and new feature of flag OUT_OF_SERVICE and STATUS_FLAG added.</a></li> <li>• Digital Outputs: new object added: <a href="#">HAND_STATUS.</a></li> <li>• Description of the new MINI module 4x Triac Outputs added: <a href="#">4TO-H</a> and <a href="#">4TO-H-IP.</a></li> <li>• <a href="#">MINI - 4I40-H and 4I40-H-IP Module built-in application:</a> Change of logic in the Time relay mode. Now the timer counts from falling edge (is used to do it from rising edge).</li> <li>• MINI - 4I40-H and 4I40-H-IP Module built-in application: new objects added <a href="#">MODE_TIME, COMMAND, and BLOCKING.</a></li> <li>• <a href="#">Short list of BACnet Objects added.</a></li> <li>• Tables with <a href="#">PT1000</a> and <a href="#">NI1000</a> updated with more accurate data, due to new FW measuring temperature at these sensors with 0.1°C accuracy.</li> </ul>
1.2	2017.01.04	<p>The reason for the creation of a new version of the document:</p> <p>New functions:</p> <ul style="list-style-type: none"> <li>• New HVAC functions Heating and Cooling in 4U4O based on output thermostatic control with a setpoint and differential value setting;</li> <li>• New input mode added for 4I4O: Time Relay NC [ms], Time Relay NO and NC in seconds, Input Forwarding;</li> <li>• New input mode added for 4U4O: Ordinary IO, Monostable Relay, Bistable</li> </ul>

		<p>Relay, Time Relay NO and NC [ms], Time Relay NO and NC in seconds, Input Forwarding, Heating, Cooling with corresponding BACnet objects and Modbus registers;</p> <ul style="list-style-type: none"> <li>• Output for resetting to default after input mode change in 4U4O and 4I4O;</li> </ul> <p>Improvements:</p> <ul style="list-style-type: none"> <li>• Improved BACnet COV Increment now can have values with the resolution of 0.1;</li> <li>• BACnet COV Increment access (read/write) through USB added;</li> <li>• Power Led added, flashing when the IO watchdog is triggered;</li> <li>• IO watchdog reset after read/write registers through USB modified;</li> <li>• Sensors added for the immediate detection of short circuit and disconnection, regardless of filter settings on universal inputs;</li> </ul> <p>Bugs fixed:</p> <p>Fixed bug with Stop bits, it was always 1;</p>
1.3	2017.05.16	<p>The reason for the creation of a new version of the document:</p> <p>New functions:</p> <ul style="list-style-type: none"> <li>• Hardware Version info added on the main tab on the web page and in the Modbus register</li> <li>• new action in the Modbus register no 0 – enter the bootloader</li> <li>• RS485 biasing control added for <b>MINI modules</b> with hardware version <math>\geq 2.0</math> (option unavailable in MIX modules)</li> <li>• new Device Object properties added: Version type, Baud rate, User Baud rate, IP address, Subnet mask, Default Gateway, HTTP port, and UDP port</li> <li>• www page: RS485 Biasing Resistors activating option (appears only in MINI modules with a hardware <math>\geq 2.0</math>)</li> </ul> <p>Improvements:</p> <ul style="list-style-type: none"> <li>• www page fixed: COV increment always in a format with one decimal place</li> <li>• module names on web page the corrected (added -H for all modules with hand operation switches)</li> </ul>
1.4	2017.12.07	<p>The reason for the creation of a new version of the document: On 07.12.2017, GC5 released a new firmware version 6.0 for MIX and MINI modules. New firmware contains a bug fix, improvements and changes in BACnet protocol, according to BACnet Testing Laboratories certification requirements.</p> <p>New functions:</p> <ul style="list-style-type: none"> <li>• Firmware Version 6.0 released with BACnet certification</li> </ul> <p>Improvements:</p> <ul style="list-style-type: none"> <li>• fixed out of service flags in AO, BO and TO</li> <li>• fixed overridden flags in AO, BO and TO</li> <li>• fixed bug with number of counters for Binary input object (now variable is 32 bit)</li> <li>• changed AO-1, BO-1, TO-1 HAND_STATUS Access to read only</li> <li>• changed resistance table for 2.2K3A1 sensor</li> </ul>
1.5	2018.10.05	<p>The reason for the creation of new version of the document:</p> <ul style="list-style-type: none"> <li>• Corrections of typing errors in the text</li> <li>• Added imperial unit of measure</li> </ul> <p>New functions:</p> <ul style="list-style-type: none"> <li>• MINI and MIX modules earned UL recognized component mark</li> </ul>

Table 1. Revision history

## 1.2 Safety rules

- **Note:** Incorrect wiring of this product can damage it and lead to other hazards. Make sure, the product has been correctly wired before turning the power ON.
- Before wiring, or removing/mounting the product, be sure to turn the power OFF. Failure to do so might result in electric shock.
- Do not touch electrically charged parts such as the power terminals. Doing so might result in electric shock.
- Do not disassemble the product. Doing so might result in electric shock or faulty operation.
- Use the product within the operating ranges recommended in the specification (temperature, humidity, voltage, shock, mounting direction, atmosphere etc.). Failure to do so might result in fire or faulty operation.
- Firmly tighten the wires to the terminal. Insufficient tightening of the wires to the terminal might cause fire.

## 1.3 EN 60730-1 Power supply considerations

- Electrical safety in the building automation and control systems is essentially based on the use of extra low voltage which is strictly separated from the mains voltage. This low voltage is either SELV or PELV according to EN 60730-1.
- Protection against electric shock is ensured by the following measures:
- limitation of voltage (low voltage AC/DC 24V supply, either SELV or PELV)
- protective-separation of the SELV-system from all circuits other than SELV and PELV
- simple-separation of the SELV-system from other SELV-systems, from PELV-systems and earth
- Field devices such as sensors, status contacts and actuators connected to the low-voltage inputs and outputs of I/O modules must comply with the requirements for SELV or PELV. The interfaces of field devices and other systems must also satisfy SELV or PELV requirements.
- When the supply of SELV or PELV circuits is obtained from supply mains of higher voltages it shall be provided by safety transformer or a converter designed for continuous operation to supply SELV or PELV circuits.

## 1.4 FCC Compliance note

Note: This equipment has been tested and found to comply with the limits for a Class B digital device, pursuant to part 15 of the FCC Rules. These limits are designed to provide reasonable protection against harmful interference in a residential installation. This equipment generates, uses and can radiate radio frequency energy and, if not installed and used in accordance with the instructions, may cause harmful interference to radio communications. However, there is no guarantee that interference will not occur in a particular installation. If this

equipment does cause harmful interference to radio or television reception, which can be determined by turning the equipment off and on, the user is encouraged to try to correct the interference by one or more of the following measures:

- Reorient or relocate the receiving antenna.
- Increase the separation between the equipment and receiver.
- Connect the equipment into an outlet on a circuit different from that to which the receiver is connected.
- Consult the dealer or an experienced radio/TV technician for help.

## 1.5 Technical specifications

<b>Power supply</b>	Voltage	24 V AC/DC $\pm$ 20%	
	Power consumption		
	Module type	@ 24 V DC	@ 24 V AC
	8I	0.4 W	0.6 VA
	8I-IP	1.4 W	2.1 VA
	8U	0.5 W	0.8 VA
	8U-IP	1.5 W	2.3 VA
	4I4O-H	1.2 W	1.8 VA
	4I4O-H-IP	2.2 W	3.3 VA
	4U4O-H	1.2 W	1.8 VA
	4U4O-H-IP	2.2 W	3.3 VA
	4U4A-H	2.2 W	3.3 VA
	4U4A-H-IP	3.2 W	4.8 VA
	4O-H	1.6 W	2.4 VA
	4O-H-IP	2.6 W	3.9 VA
	4TO-H	1.0 W	1.5 VA
	4TO-H-IP	2.0 W	3.0 VA
	MIX18	3.0 W	4.5 VA
	MIX18-IP	4.4 W	6.6 VA
MIX38	5.0 W	7.5 VA	
MIX38-IP	7.4 W	11.1 VA	
<b>Universal Inputs</b>	Temperature input	<ul style="list-style-type: none"> <li>• Measurement with RTDs attached</li> <li>• accuracy <math>\pm</math> 0.1°C</li> <li>• For PT1000 and NI1000 sensors use 16-bit resolution</li> </ul>	
	Voltage input	<ul style="list-style-type: none"> <li>• Voltage measurement in 0-10 V DC range</li> <li>• Input impedance 100 k<math>\Omega</math></li> <li>• Measurement accuracy <math>\pm</math>0.1%</li> <li>• Measurement resolution 3 mV @ 12-bit and 1 mV @ 16-bit</li> </ul>	
	Current input	<ul style="list-style-type: none"> <li>• Current measurement in 0 - 20 mA range</li> <li>• Required external resistor 200 <math>\Omega</math></li> <li>• Measurement accuracy <math>\pm</math>1.1%</li> <li>• Measurement resolution 15 <math>\mu</math>A @ 12-bit and 5 <math>\mu</math>A @ 16-bit</li> </ul>	
	Resistive input	<ul style="list-style-type: none"> <li>• Measurement of resistance in 0 to 1000 k<math>\Omega</math> range</li> <li>• Measurement resolution for 20 k<math>\Omega</math> load 20 <math>\Omega</math> @ 12-bit and 1 <math>\Omega</math> @ 16-bit</li> <li>• Measurement resolution for PT1000 and NI1000 0.1 <math>\Omega</math> @ 16-bit</li> </ul>	
	Resistance measurement method	Voltage divider	
	Dry contact input	Output current $\sim$ 1 mA	
	Measurement resolution	12-bits (default) or 16-bits	



	Processing time	<ul style="list-style-type: none"> <li>10 ms/channel at 12-bits</li> <li>140 ms/channel at 16-bits</li> </ul>	
<b>Digital Inputs</b>	Type	Dry contact	
	Max input frequency	100 Hz save in EEPROM memory	
<b>Analog Outputs</b>	Voltage range	0-10 V DC	
	Max. load current	20 mA, total 60mA load current for all outputs for MIX18, MIX18-IP, MIX38, MIX38-IP modules	
	Resolution	12-bit	
	Accuracy	± 0.5%	
<b>Digital Outputs (relays)</b>	Contact material	AgSnO <sub>2</sub>	
		UL compliant ratings	Maximum ratings
	Resistive load AC1	3 A @ 24 V AC 3 A @ 30 V DC	3 A @ 230 V AC 3 A @ 30 V DC
	Inductive load AC3	8 VA @ 24 V AC 30 W @ 30 V DC	75 VA @ 230 V AC 30 W @ 30 V DC
	Capacitive load		50 W @ LED + PS 230 VAC 100 W @ fluorescent lamps with electronic ballast 75 W @ CFL Compact fluorescent lamp
<b>Digital Outputs (relays) 40-H and 40-H-IP</b>	Contact material	AgSnO <sub>2</sub>	
		UL compliant ratings	Maximum ratings
	Resistive load AC1	8 A @ 230 V AC 8 A @ 30 V DC	8 A @ 230 V AC 8 A @ 30 V DC
	Inductive load AC3	37 VA @ 230 V AC 90 W @ 30 V DC	360 VA @ 230 V AC 90 W @ 30 V DC
	Capacitive load		180 W @ CFL Compact fluorescent lamp 120 W @ LED + PS 230 V AC 240 W @ fluorescent lamps with electronic ballast
<b>Triac Outputs</b>	Continuous load per channel	0.5 A @ 20 V AC up to max. 250 V AC	
	Peak load per channel	1.5 A @ 20 V AC up to max. 250 V AC (30s)	
	Gate Control	Zero crossing turn ON	
	Frequency Range	47 to 63 Hz	
	Snubber	Snubberless Triac	
<b>RS485 Interface</b>	RS485	Up to 128 devices	
	Communication protocols	Modbus RTU, Modbus ASCII or BACnet set by switch	
	Baud rate	From 2400 to 115200 set by switch	
	Address	0 to 99 set by switch	
<b>Ethernet</b>	MIX18-IP, MIX38-IP		
	2x Fast Ethernet	Switch mode	
	Baud rate	10/100 Mb/s	

<b>USB</b>	8I-IP, 8U-IP, 4I4O-H-IP, 4U4O-H-IP, 4U4A-H-IP, 4O-H-IP, TO-H-IP	
	1x Fast Ethernet	IP Interface
	Baud rate	10/100 Mb/s
	USB	Mini USB 2.0
<b>Ingress protection</b>	IP	IP40
<b>Temperature</b>	Storage	-40°C to +85°C (-40°F to 185°F)
	Operating	-10°C to +50°C (14°F to 122°F)
<b>Humidity</b>	Relative	5% to 95%
<b>Connectors</b>	Type	Removable
	Maximum cable size	2.5 mm <sup>2</sup> (18 – 12 AWG)
	Maximum tightening torque	0,35 Nm
<b>Dimensions</b>	MIX18, MIX18-IP	
	Width	110 mm (4.331 in)
	Length	88 mm (3.4646 in)
	Height	62 mm (2.441 in)
	MIX38, MIX38-IP	
	Width	110 mm (4.331 in)
	Length	160 mm (6.2993 in)
	Height	62 mm (2.441 in)
	MINI Series	
	Width	110 mm (4.331 in)
	Length	37 mm (1.457 in)
	Height	62 mm (2.441 in)

Table 2. Technical specifications

## 1.6 Summary table for all modules

Module type	UI	DI	AO	DO	TO	Modbus RS485	Modbus TCP/IP	BACnet MSTP	BACnet IP
4I4O-H		4		4		✓		✓	
4I4O-H-IP		4		4			✓		✓
4O-H				4 (NC/NO-8A)		✓		✓	
4O-H-IP				4 (NC/NO-8A)			✓		✓
4U4A-H	4		4			✓		✓	
4U4A-H-IP	4		4				✓		✓
4U4O-H	4			4		✓		✓	
4U4O-H-IP	4			4			✓		✓
8I		8				✓		✓	
8I-IP		8					✓		✓
8U	8					✓		✓	
8U-IP	8						✓		✓
4TO-H					4	✓		✓	
4TO-H-IP					4		✓		✓

<b>MIX18</b>	5	5	4	4		✓		✓	
<b>MIX18-IP</b>	5	5	4	4			✓		✓
<b>MIX38</b>	8	12	6	12		✓		✓	
<b>MIX38-IP</b>	8	12	6	12			✓		✓
						RTU ASCII	Modbus Gateway IP/RS485	Master Slave	

Table 3. Summary table for all modules

## 1.7 Dimensions

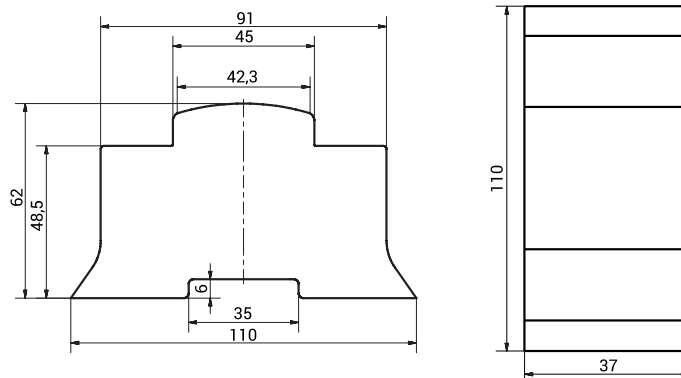

Figure 1. MINI series dimensions

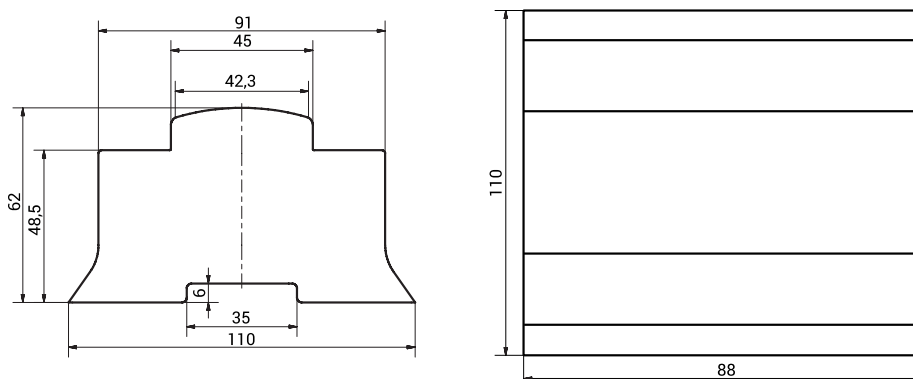

Figure 2. MIX18 and MIX18-IP dimensions

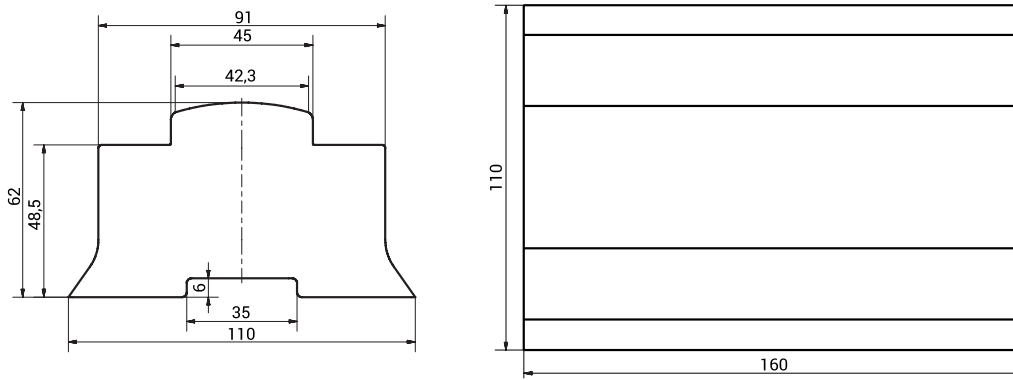

Figure 3. MIX38 and MIX38-IP dimension

## 1.8 Power supply connection

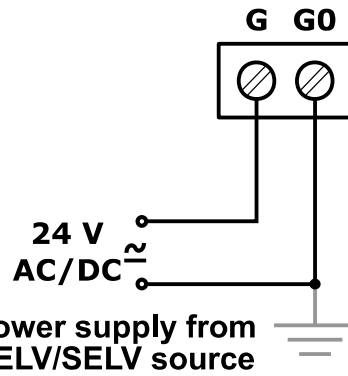

Figure 4. AC/DC power supply connection

## 1.9 Connecting the communication bus (RS485)

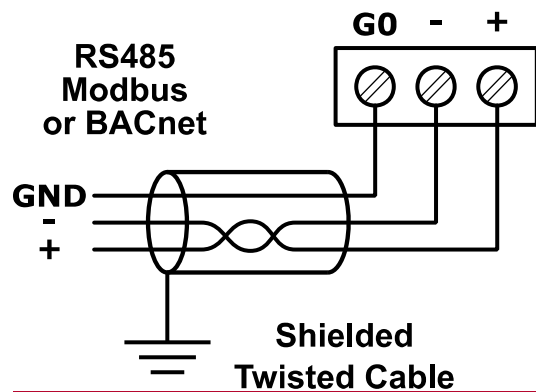

Figure 5. RS485 connection



## 1.10 LED Indicators

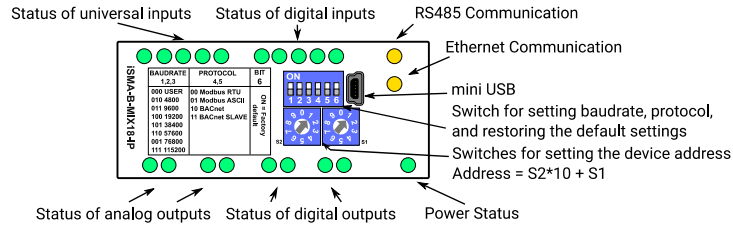

Figure 6. Top panel MIX 18 and MIX18-IP

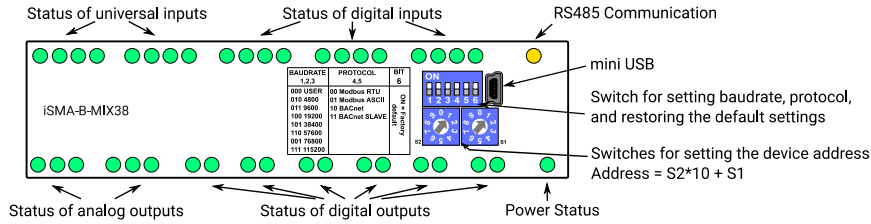

Figure 7. Top panel MIX38 and MIX38-IP

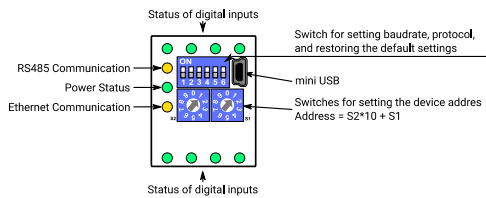

Figure 8. Top panel 8I and 8I-IP

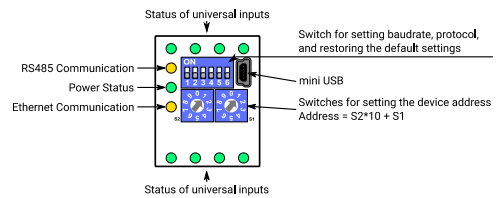

Figure 9. Top panel 8U and 8U-IP

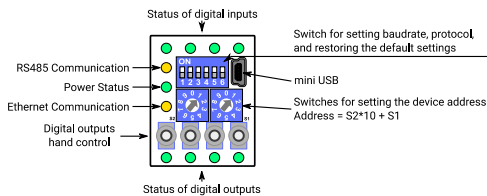

Figure 5. Top panel 4I40-H and 4I40-H-IP

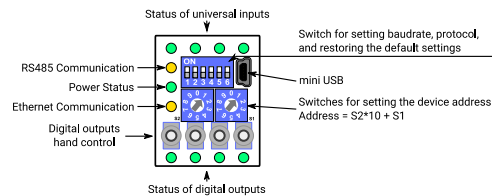

Figure 6. Top panel 4U40-H and 4U40-H-IP

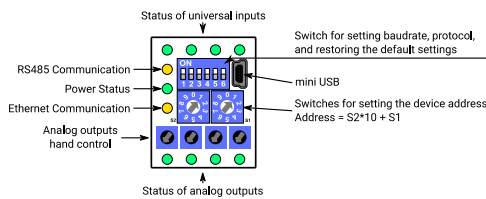

Figure 72. Top panel 4U4A-H and 4U4A-H-IP

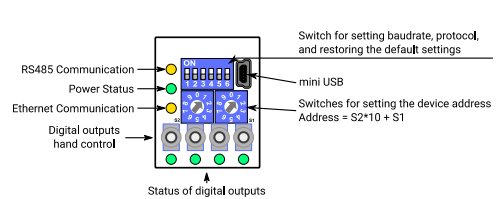

Figure 83. Top panel 4O-H and 4O-H-IP

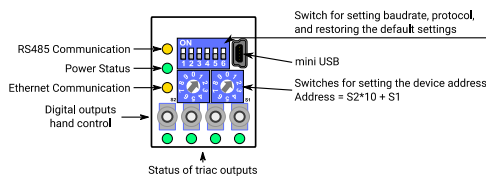

Figure 94. Top panel 4TO-H and 4TO-H-IP

- The power LED is ON (green) when the module runs properly.
- Communication LED is ON (orange) for 20 ms after sending each message. If the module receives/sends a lot of messages, LED can be lit continuously.
- LEDs indicating the status of the Universal Inputs are lit when the resistance connected to the input is less than 5 k $\Omega$  (Dry Contact input is active).

**WARNING!** The LED also lights up when the voltage connected to the input has a very low potential.

- LEDs indicating the status of the Digital Inputs are lit when the input is active.
- LEDs indicating the status of the Analog Outputs are lit when the output voltage or PWM duty cycle is greater than 0.
- LEDs indicating the status of the Digital Outputs are lit when the output is enabled.

## 1.11 General wiring rules

In most cases, IO modules will be installed in an enclosure along with the other devices which generate electromagnetic radiation. Relays, contactors, transformers, motor invertors etc. are the examples of these devices. Radiation can induce electrical noise into both power and signal lines, as well as direct radiation into the module. Whether or not the iSMA modules are immune to such effects, the interferences must be suppressed at their source if possible to ensure proper functioning of the entire system. Appropriate grounding, shielding and other protective steps should be taken at the installation stage to prevent these effects. It is recommended to at least follow the rules below:

- Line power cables must be routed with spatial separation from signal and data transmission cables.
- Analogue and digital signal cables should also be separated.
- It is recommended to use shielded cables for analogue signals, cable shields should not be interrupted by intermediate terminals.
- The shielding should be earthed directly after the cable enters the cabinet.
- It is recommended to install interference suppressors when switching inductive loads (e.g. coils of contactors, relays, solenoid valves). RC snubbers or varistors are suitable for AC voltage and freewheeling diodes for DC voltage loads. The suppressing elements must be connected as close to the coil as possible

## 1.12 RS485 network termination

Transmission line often causes problems in data communication networks. These problems include reflections and signal attenuation.

To eliminate the presence of reflections from the end of the cable, it must be terminated at both ends with a resistor across the line in accordance with its characteristic impedance. Both ends must be terminated since the direction of propagation is bidirectional. In case of using an RS485 twisted pair cable, this termination is typically 120  $\Omega$ .

## 1.13 Setting Module MAC

The module is equipped with two rotary switches S1 and S2, located on the top panel of the device, for determining the MAC of the device.

It is possible to set the MAC within the range from 0 to 99 in BACnet protocol mode or from 128 to 227 in BACnet SLAVE protocol mode (128 + switch value). The formula for setting the MAC is as follows:

$$\text{MAC} = \text{S2} \cdot 10 + \text{S1}$$

where S1 and S2 are the values of the switches.

Example of **BACnet Master protocol mode**:

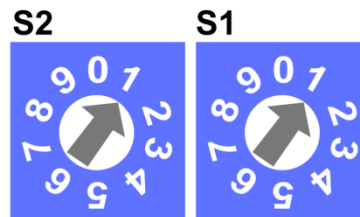

Figure 15. Exemplary MAC setting in Master mode

Switches set as in the figure above will set the MAC module to 11.

Example for **BACnet Slave protocol mode** (only RS485 modules; IP modules do not support BACnet Slave):

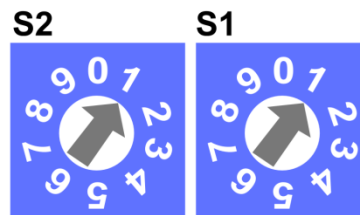

Figure 16. Exemplary MAC setting in Slave mode

Switches set as in the picture above will set the MAC module to 139 (128+11).

## 1.14 Setting Device ID

Formula for Device ID:

$$\text{Device ID} = \text{Vendor ID} \cdot 1000 + \text{MAC} + 128 \quad (\text{only in BACnet SLAVE})$$

where **GC5** Vendor ID = 826.

For example: If MAC is set to 41 and protocol is set to BACnet Master, then Device ID = 826041 or id protocol is set to BACnet SLAVE, then Device ID = 826169.

If the user changes the Device ID (by setting a new value of Device ID property in Device object) then changing MAC with rotary switches will not change the Device ID. In order for changing the Device ID to be modified again by changing MAC, the device needs to be restored to Default Settings.

## 1.15 Baud rate selection

Transmission baud rate is set with S3 switch (sections 1, 2, and 3) in accordance with the



following table:

1	2	3	Baud rate
OFF (0)	OFF (0)	OFF (0)	Defined by the user in the registry
OFF (0)	OFF (0)	ON (1)	76800
OFF (0)	ON (1)	OFF (0)	4800
OFF (0)	ON (1)	ON (1)	9600
ON (1)	OFF (0)	OFF (0)	19200
ON (1)	OFF (0)	ON (1)	38400
ON (1)	ON (1)	OFF (0)	57600
ON (1)	ON (1)	ON (1)	115200

Table 4. Baud rate selection

## 1.16 Protocol selection

The protocol is selected with sections 4 and 5 of the S3 switch according to the table:

4	5	Protocol
OFF (0)	OFF (0)	Modbus RTU
OFF (0)	ON (1)	Modbus ASCII
ON (1)	OFF (0)	BACnet Master
ON (1)	ON (1)	BACnet Slave

Table 5. Protocol selection

**WARNING!** BACnet SLAVE mode does not support the discover function.

## 1.17 Restoring the default settings

To restore the default configuration of all registers, follow the steps below:

- Turn off the power supply;
- Set section 6 of S3 switch to ON;
- Turn on the power supply, power LED will start blinking;
- Switch section 6 of S3 switch to OFF to restore the default settings. To cancel the reset, turn off the power and switch section 6 of S3 switch to the OFF position.

## 1.18 Default Settings

In its out-of-the-box state, as well as after restoring the default values, the device has got the following default register values:

Register Name	Default Value
COUNTER 1 – 12	0
USER BAUD RATE	7680 (76800 bps)

STOP BITS	1
DATA BITS	8
PARITY BITS	0
RESPONSE DELAY	0
WATCHDOG TIME	0 (disabled)
DEFAULT STATE OF DIGITAL OUTPUTS (1-12)	0
DEFAULT STATE OF THE ANALOG OUTPUTS (DIGITAL 1-6)	0
DEFAULT STATE OF THE ANALOG OUTPUTS (1-6)	0
UNIVERSAL INPUT CONFIGURATION (1-8)	1
INPUT FILTER TIME CONSTANT (1-8)	2
UNIVERSAL INPUT RESOLUTION (1-8)	0
ANALOG OUTPUT CONFIGURATION (1-6)	0
COV INCREMENT (BACnet only)	1
<b>Only for IP Modules</b>	
USERNAME	admin
PASSWORD	1000
IP ADDRESS	192.168.1.123
MASK	255.255.255.0
GATEWAY	192.168.1.1
HTTP PORT	80
MODBUS TCP PORT	502
MODBUS TCP TIMEOUT	60s
RS485 TIMEOUT	1000 ms
SEND MODBUS ERRORS	DISABLED
BACNET ID	826001
BACNET UDP PORT	47808 (0xBAC0)

Table 6. Default values

## 2 Conformance statement regarding the implementation of the protocol

**WARNING!** Changing the parameters regarding the configuration of the transmission will only take effect after restarting the unit (except for the registers the value of which is read from the switch).

### 2.1 Conformance Statement regarding BACnet Protocol Implementation

<b>Date</b>	2016-01-07
<b>Vendor Name</b>	Global Control 5 Sp. z o.o.
<b>Product Name</b>	iSMA-B-MIX iSMA-B-MINI
<b>Product Model Number</b>	iSMA-B-MIX18 iSMA-B-MIX38 iSMA-B-8I iSMA-B-8U iSMA-B-4O-H iSMA-B-4I4O-H iSMA-B-4U4O-H iSMA-B-4U4A-H iSMA-B-4TO-H iSMA-B-MIX18-IP iSMA-B-MIX38-IP iSMA-B-8I-IP iSMA-B-8U-IP iSMA-B-4O-H-IP iSMA-B-4I4O-H-IP iSMA-B-4U4O-H-IP iSMA-B-4U4A-H-IP iSMA-B-4TO-H-IP
<b>Firmware Revision</b>	6.0
<b>BACnet Protocol Revision</b>	1.14

Table 7. Conformance statement regarding BACnet Protocol Implementation

### 2.2 BACnet Standardized Device Profile

All I-O modules have been standardized as BACnet Smart Sensors (B-SS).

### 2.3 Supported BACnet Interoperability Building Blocks

Application Service (B-SS)	Designation
Data Sharing - Read Property – B	DS-RP-B
Data Sharing - Write Property - B	DS-WP-B
Data Sharing - COV - B	DS-COV-B
Device Management - Dynamic Device Binding - B	DM-DDB-B
Device Management - Dynamic Object Binding - B	DM-DOB-B
Data Sharing - Read Property Multiple – B	DS-RPM-B
Data Sharing - Write Property Multiple – B	DS-WPM-B

Table 8. Building Blocks Supported

## 2.4 Supported BACnet Standard Object Types

The following is a list of the standard object types as defined by ASHRAE.

Object Name	Object Numbers for different type of modules								
	8U, 8U-IP	8I, 8I-IP	4I4O-H, 4I4O-H- IP	4U4O-H, 4U4O-H- IP	4U4A-H, 4U4A-H- IP	4O-H, 4O-H- IP	4TO-H, 4TO-H- IP	MIX18, MIX18- IP	MIX38, MIX38- IP
Analog Input	8			4	4			5	8
Analog Output					4		4	4	6
Analog Value	9	9	10	6	10	2	2	12	22
Binary Input		8	4					5	12
Binary Output			4	4		4	4	4	12
Binary Value	8		8	4	4			5	8
Multistate Value	16		8	12	16	4	8	14	22
Accumulator		8	4					5	12
Device	1	1	1	1	1	1	1	1	1

Table 9. Object types supported by the modules

## 2.5 Data Link Layer Option

- Master-Slave/Token-Passing (MS/TP) master (Clause 9), baud rates: 2400, 4800, 9600, 19200, 38400, 57600, 76800, and 115200
- MS/TP slave (Clause 9), baud rates: 2400, 4800, 9600, 19200, 38400, 57600, 76800, and 115200
- BACnet Internet Protocol (IP) (Annex J)
- BACnet IP (Annex J), Foreign Device

## 2.6 Character Sets Supported

ANSI X3.4

## 2.7 Supported Application Services

Application Service	Initiates Requests	Executes Requests
I-Am	yes	
I-Have	yes	
ReadProperty		yes
ReadPropertyMultiple		yes
Who-Has		yes
Who-Is		yes
WriteProperty		yes
WritePropertyMultiple		yes

Table 10. Supported Application Services

## 2.8 About COV

All MIX and MINI modules support COV (change of value) policy. It means that the module can send a value every time it is changed. COV only works with BI, BO, AI and AO objects. For Binary Input and Binary Output objects, the values are sent with every change. Analog Input and Analog Output objects have special COV Increment property which defines additional sending criteria - object's value is sent if it is changed by COV increment value.

## 2.9 Device BACnet Objects

### 2.9.1 Device BACnet Object description

Dynamically Creatable: No, Dynamically Deletable: No

Property Name	Required	Proprietary	Writeable	Property ID	Data Type	Description
OBJECT_IDENTIFIER	Yes					
OBJECT_NAME	Yes					
OBJECT_TYPE	Yes					
SYSTEM_STATUS	Yes					
VENDOR_NAME	Yes					
VENDOR_IDENTIFIER	Yes					
MODEL_NAME	Yes					
FIRMWARE_REVISION	Yes					
APPLICATION_SOFTWARE_VERSION	Yes					
PROTOCOL_VERSION	Yes					
PROTOCOL_REVISION	Yes					
PROTOCOL_SERVICES_SUPPORTED	Yes					
PROTOCOL_OBJECT_TYPES_SUPPORTED	Yes					
OBJECT_LIST	Yes					
MAX_APDU_LENGTH_ACCEPTED	Yes					
SEGMENTATION_SUPPORTED	Yes					
APDU_TIMEOUT	Yes					
NUMBER_OF_APDU_RETRIES	Yes					
MAX_MASTER	Yes		yes			
MAX_INFO_FRAMES	Yes					
DEVICE_ADDRESS_BINDING	Yes					
DATABASE_REVISION	Yes					
ACTIVE COV SUBSCRIPTION	Yes					
HW_VERSION		yes		3020	Unsigned	
VERSION_TYPE		yes	yes	3030	Unsigned	
RS485_BIASING		yes	yes	3045	Unsigned	MINI modules only with HW_VERSION >= 2.0
BAUD_RATE		yes		3084	Unsigned	
USER_BAUD_RATE		yes	yes	3085	Unsigned	
IP_ADDRESS		yes	yes	3101	Unsigned	
SUBNET_MASK		yes	yes	3102	Unsigned	
DEFAULT_GATEWAY		yes	yes	3103	Unsigned	

Property Name	Required	Proprietary	Writeable	Property ID	Data Type	Description
HTTP_PORT		yes	yes	3104	Unsigned	
UDP_PORT		yes	yes	3105	Unsigned	
WATCHDOG		yes	yes	5001	Unsigned	
VALID_FRAMES_FOR_US_CNT		yes		5101	Unsigned	
VALID_FRAMES_NOT_FOR_US_CNT		yes		5102	Unsigned	
ERROR_FRAMES_CNT		yes		5103	Unsigned	
TRANSMITTED_FRAMES_CNT		yes		5104	Unsigned	

Table 11. Device BACnet Object

### 2.9.2 VALID\_FRAMES\_FOR\_US\_CNT Property 5101

This property contains the number of valid frames (on MS/TP layer) addressed to this module.

### 2.9.3 VALID\_FRAMES\_FOR\_NOT\_US\_CNT Property 5102

This property contains the number of valid frames (on MS/TP layer) which are not addressed to this module.

### 2.9.4 ERROR\_FRAMES\_CNT Property 5103

This property contains the number of invalid frames on MS/TP layer.

### 2.9.5 TRANSMITTED\_FRAMES\_CNT Property 5104

This property contains the number of transmitted frames.

### 2.9.6 UP\_TIME Object (Analog Value: 0)

This object shows the time of module operation module in seconds from the last power-up or module reset.

### 2.9.7 WATCHDOG Object (Analog Value: 1)

This object specifies the time in seconds to watchdog reset. If the module does not receive any valid BACnet message within that time, all PRIORITY\_ARRAYs will be set to null and PRESENT\_VALUE for outputs will be set to RELINQUISH\_DEFAULT value.

This feature is useful in case of an interruption in data transmission and if for security reasons output states must be set to the appropriate state to avoid endangering the safety of persons or property.

The default value is 0 seconds which means the watchdog function is disabled. To maintain compatibility this object is also available as Device object property 5001.

When the watchdog is triggered the Power LED blinks with the specified sequence (3 blinks with 20Hz frequency and 1 second pause).

### 2.9.8 FIRMWARE VERSION AND MODULE TYPE Property 3030

The property contains type and firmware version of a module.

The low byte contains information about a type of a module in accordance with the table below:

Value	Type
81 <sub>10</sub> (0x51 <sub>16</sub> )	8I
91 <sub>10</sub> (0x5B <sub>16</sub> )	8I-IP
84 <sub>10</sub> (0x54 <sub>16</sub> )	8U
94 <sub>10</sub> (0x5E <sub>16</sub> )	8U-IP
83 <sub>10</sub> (0x53 <sub>16</sub> )	4I4O-H
93 <sub>10</sub> (0x5D <sub>16</sub> )	4I4O-H-IP
85 <sub>10</sub> (0x55 <sub>16</sub> )	4U4O-H
95 <sub>10</sub> (0x5F <sub>16</sub> )	4U4O-H-IP
86 <sub>10</sub> (0x56 <sub>16</sub> )	4U4A-H
96 <sub>10</sub> (0x60 <sub>16</sub> )	4U4A-H-IP
82 <sub>10</sub> (0x52 <sub>16</sub> )	4O-H
92 <sub>10</sub> (0x5C <sub>16</sub> )	4O-H-IP
87 <sub>10</sub> (0x57 <sub>16</sub> )	4TO-H
97 <sub>10</sub> (0x61 <sub>16</sub> )	4TO-H-IP
50 <sub>10</sub> (0x32 <sub>16</sub> )	MIX18
51 <sub>10</sub> (0x33 <sub>16</sub> )	MIX38
52 <sub>10</sub> (0x34 <sub>16</sub> )	MIX18-IP
53 <sub>10</sub> (0x35 <sub>16</sub> )	MIX38-IP

Table 12. Module type value assignment.

The high byte contains a module firmware version multiplied by 10.

#### Example:

The property 3030 has a value of 12810<sub>10</sub> = 0x320A<sub>16</sub>. It means that it is a MIX18 module (0x32) with a firmware version 1.0 (0x0A<sub>16</sub> = 10<sub>10</sub>).

Setting property 3030 according to the table below will enable 1 of 4 available actions: reset module, reload settings, set to default, and enter the bootloader.

Value	Action
511	Reset



767	Reload settings
1023	Set to default
1279	Enter the bootloader

Table 13. Device actions.

### 2.9.9 RS485\_BIASING Property 3045

The property allows to activate RS485 biasing resistors in order to pull-up voltage on the RS485 bus. The function is **only** available in **MINI modules** with a hardware version  $\geq$  2.0 (option unavailable in MIX modules).

The biasing resistors are useful in case when iSMA modules are connected to third party devices with the same RS485 bus and communication errors appear on the network.

**WARNING!** Only one device in the network can have biasing resistors activated!

### 3 Local I/O

#### 3.1 Universal Inputs connections

##### 3.1.1 Connection of Universal Input to measure voltage 0 – 10 V

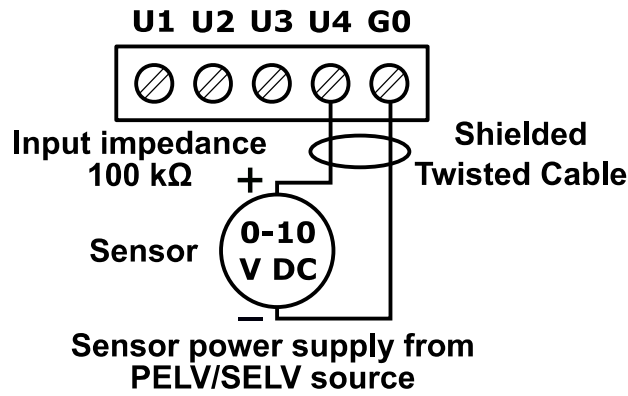

Figure 10. Connection of UI to measure 0-10 V DC for MIX38 and MIX38-IP

##### 3.1.2 Connection of the Universal Input to measure current 0 – 20 mA

Current measurement is performed by measuring the voltage and 200 Ω resistance. According to Ohm's law, the current is directly proportional to the voltage and the resistance as the constant of proportionality.

$$I = \frac{U}{R}$$

According to the Ohm's law equation for 20mA current with 200Ω resistance the output voltage is 4V, which means that the voltage of 4V on the Universal Input corresponds with 20mA current.

The result is expressed in millivolts.

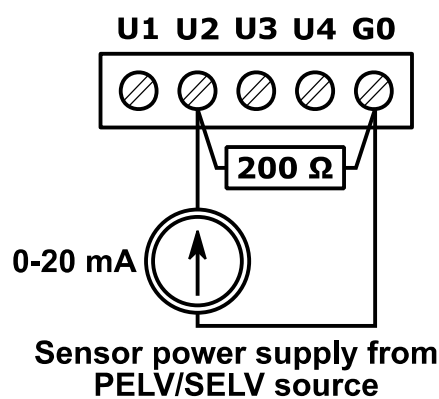

Figure 18. Connection of UI to measure 0-20mA for MIX38 and MIX38-IP

### 3.1.3 Connection of Universal Input to measure the temperature

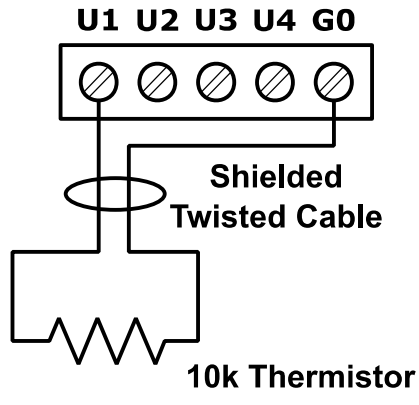

Figure 11. Connection of UI to measure the temperature for MIX18 and MIX18-IP

### 3.1.4 Connection of Universal Input as a Digital Input (Dry Contact)

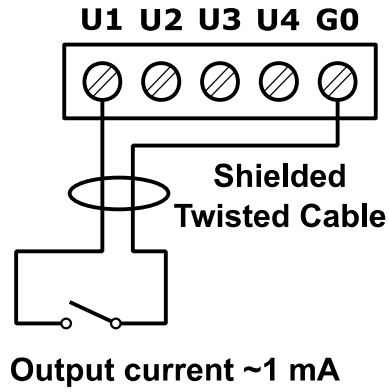

Figure 120. Connection of UI for operating as DI for MIX38 and MIX38-IP

## 3.2 Universal Input BACnet objects

### 3.2.1 UI - Universal Input object description (Analog Input: 0 - 7)

Each Universal Input of all types of modules is represented on the BACnet network as BACnet Analog Input Object with the following properties:

Dynamically Creatable: No, Dynamically Deletable: No

Property Name	Required	Proprietary	Writeable	Property ID	Data Type	Description
OBJECT_IDENTIFIER	yes					from AI:0 to AI-7
OBJECT_NAME	yes					UI-x
OBJECT_TYPE	yes					
PRESENT_VALUE	yes					PRESENT_VALUE and UNITS Property
STATUS_FLAGS	yes					
EVENT_STATE	yes					
OUT_OF_SERVICE	yes					OUT OF SERVICE Property
UNITS	yes					PRESENT_VALUE and UNITS Property
COV_INCREMENT						COV INCREMENT Property
INPUT_TYPE *		yes	yes	4001	Enumerated	UI CONFIGURATION Object (Multistate Value: 1 – 8)
RESOLUTION *		yes	yes	4002	Enumerated	
FILTER *		yes	yes	4003	Unsigned	
VOLTAGE *		yes		3010	Unsigned	
RESISTANCE *		yes		3012	Unsigned	
DRY_CONTACT *		yes		3013	Enumerated	

Table 14. Properties of BACnet Analog Input Object

\* Object additional properties are saved to keep the backward compatibility with the older firmware version. In new firmware version, each property has a corresponding BACnet object.

#### 3.2.1.1 PRESENT\_VALUE and UNITS Property

This property contains actual value and unit of universal input according to INPUT\_TYPE property value. The units for the Present Value are defined by UI\_CONFIGURATION object.

#### 3.2.1.2 COV INCREMENT Property

In firmware version above, 4.0 MIX and MINI modules support COV (change of value),

which means that the module will automatically send Analog Input value if it changes more than COV Increment property value (in IP modules this value can be also changed from the module web page).

### 3.2.1.3 OUT OF SERVICE Property

When Out Of Service is false, Present Value property represents actual value read from the input. Setting the Out Of Service property to the true will stop updating the Present Value property allowing writing a custom value to it. That custom value will then override the value read from the physical input.

**WARNING!** If you try to override the Present value when Out Of Service is false, the module will return an error message: “Write Access Denied”.

### 3.2.2 UI CONFIGURATION Object (Multistate Value: 1 – 8)

This object is used to set the type of the Universal Input. Changing the Input type and Analog Input Units property (voltage, resistance or sensor type) also has an impact on UI object Units.

Object value	Description	Unit Property
1	Voltage measurement 0-10 V	mV
2	Resistance input	Ω
3 (default)	The temperature sensor 10K3A1 NTC B=3975K	°C
4	The temperature sensor 10K4A1 NTC B=3695K	°C
5	The temperature sensor 10K NTC B=3435K Carel	°C
6	The temperature sensor 20K6A1 NTC B=4262K	°C
7	The temperature sensor 2,2K3A1 NTC B=3975K	°C
8	The temperature sensor 3K3A1 NTC B=3975K	°C
9	The temperature sensor 30K6A1 NTC B=4262K	°C
10	The temperature sensor SIE1	°C
11	The temperature sensor TAC1	°C
12	The temperature sensor SAT1	°C
13	The temperature sensor Pt1000	°C
14	The temperature sensor Ni1000	°C

Table 15. UI CONFIGURATION Object value list

This parameter is also available as BACnet UI Analog Input object property number 4001. For configuration parameters, please refer to Modbus Manual register numbers 40151 – 40158.

### 3.2.3 UI RESOLUTION Object (Multistate Value: 9 – 16)

This object is used to determine the bit resolution for each of the 12- and 16-bit Universal Inputs.

Setting the value to 1 will set the resolution of the converter to 12-bit. Setting the value to 2 sets the resolution of the converter to 16-bit.

Object value	Description
1 (default)	12-bit
2	16-bit

Table 16. UI RESOLUTION Object value list

**WARNING!** Setting 16-bit resolution increases the measurement time of one channel from 10ms to 140ms. Total time necessary to measure all the channels increases from 80ms to 1120ms.

This parameter is also available as BACnet UI Analog Input object property number 4002.

### 3.2.4 UI FILTER Object (Analog Value: 14 – 21)

This object is used to determine the time constant of low pass filter. The value is expressed in seconds. Valid values must be between 0 and 60 seconds. The default value is 2 seconds. Setting value to 0 will disable the filter.

This parameter is also available as BACnet UI Analog Input object property number 4003.

In case of UI shortcut or open-loop, the filter is reset and UI value filtering is stopped.

### 3.2.5 UI DRY\_CONTACT Object (Binary Value: 0 – 7)

This object contains information about the status of Digital Inputs (dry contact). When the input is shorted to the ground, the value is set to 1. UI\_DRY\_CONTACT object works only if UI\_CONFIGURATION object is set to resistance or temperature.

This status is also available as BACnet UI Analog Input object property number 3013.

### 3.3 Digital Inputs connections

#### 3.3.1 Connection of Digital Input (Dry Contact)

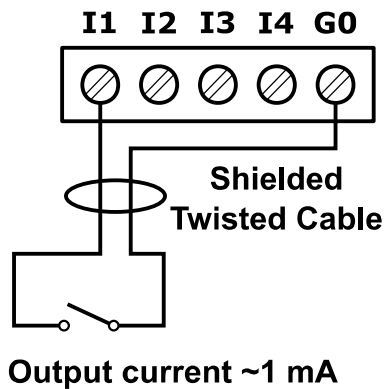

Figure 21. DI connection for MIX38 and MIX38-IP

### 3.4 Digital Input BACnet objects

#### 3.4.1 BI - Digital Input object description (Binary Input: 0 - 11)

Each of the Digital Input of all types of modules is represented on the BACnet network as a BACnet Binary Input Object with the following properties:

Dynamically Creatable: No, Dynamically Deletable: No

Property Name	Required	Proprietary	Writable	Property ID	Data Type	Description
OBJECT_IDENTIFIER	Yes					from BI:0 to BI:11
OBJECT_NAME	yes					BI-x
OBJECT_TYPE	yes					
PRESENT_VALUE	yes					PRESENT_VALUE Property
STATUS_FLAGS	yes					
EVENT_STATE	yes					
OUT_OF_SERVICE	yes					OUT OF SERVICE Property
POLARITY	Yes					
UNITS	Yes					
COUNTER *		yes	yes	3001	unsigned	

Table 17. Properties of BACnet Binary Input Object

\* Object additional properties are saved to maintain the backward compatibility with the older firmware version. In the new firmware version, each of the properties has a corresponding BACnet object.

### 3.4.1.1 PRESENT\_VALUE Property

This property contains the status of the Digital Inputs. Shorting the input to G0 sets the value to 1.

### 3.4.1.2 Binary Input COV

In firmware version above 4.0, MIX and MINI modules support COV (change of value). It means that the module will automatically send Digital Input value after every change.

### 3.4.1.3 OUT OF SERVICE Property

When Out Of Service is false, the Present Value property represents actual value read from the input. Setting Out Of Service property to true, will stop updating Present Value property from the physical input and will allow for entering a custom value into the Present Value property.

**WARNING!** If you override the Present Value when Out Of Service is false, the module will return an error message: "Write Access Denied".

## 3.4.2 BIA COUNTER Object (Accumulator: 0 – 12)

This object contains the number of counted pulses represented by Accumulator Value BACnet object. This value is also saved in the non-volatile memory, so the information is stored even after the power cycle finishes. It is possible to reset the counter by entering 0 to the Present Value property of this object.

This value is also available as BACnet BI Binary Input object property number 3001.

## 3.4.3 BI COUNTER Object (Analog Value: 2 – 13)

This object contains the number of counted pulses identical to Accumulator BACnet object, but stored as Analog Value object. Not every system supports accumulator type object, therefore we have created additional objects for the counters. Analog Value has one drawback - Odd values above 16777216 will be rounded down by 1. For example: 16777216 + 1 will still be shown as 16777216, but 16777216 + 2 will be shown properly as 16777218.



### 3.5 Analog Outputs connections

#### 3.5.1 Connection of Analog Output 0 – 10 V

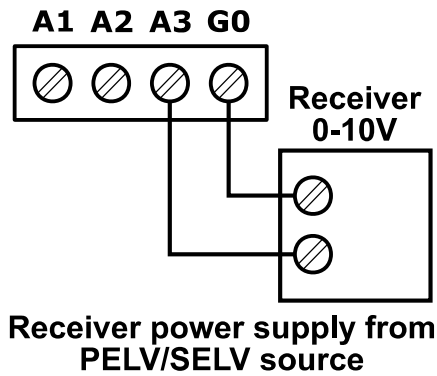

Figure 13. Connection of AO for MIX38 and MIX38-IP

#### 3.5.2 Connecting relay to the Analog Output

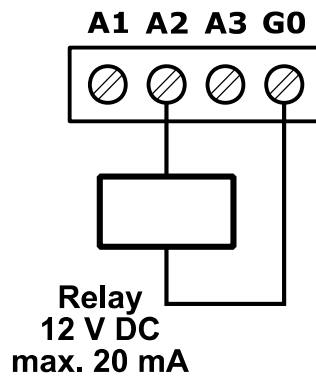

Figure 23. Connection of AO to the relay for MIX38 and MIX38-IP

#### 3.5.3 Connecting an actuator to the Analog Output

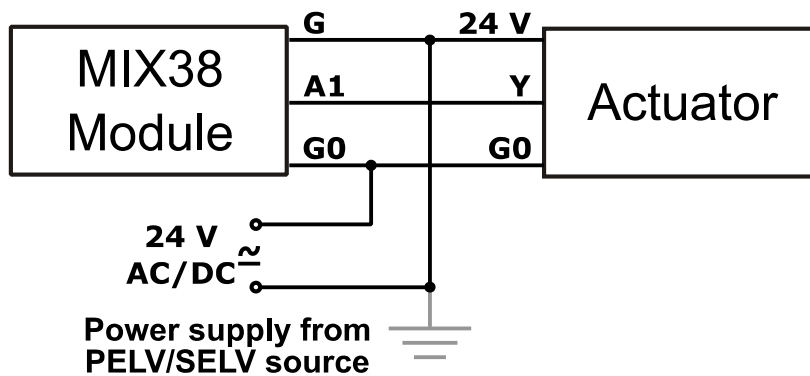

Figure 24. Connection of actuator to AO

## Analog Output BACnet objects

### 3.5.4 AO - Analog Output object description (Analog Output: 0 - 5)

Each of the Analog Outputs for all types of modules is represented on BACnet network as BACnet Analog Output Object with the following properties:

Dynamically Creatable: No, Dynamically Deletable: No

Property Name	Required	Proprietary	Writeable	Property ID	Data Type	Description
OBJECT_IDENTIFIER	yes					from AO:0 to AO:5
OBJECT_NAME	yes					AO-x
OBJECT_TYPE	yes					
PRESENT_VALUE	yes		yes			PRESENT_VALUE Property
STATUS_FLAGS	yes					STATUS FLAG Property
EVENT_STATE	yes					
OUT_OF_SERVICE	yes		yes			OUT OF SERVICE Property
UNITS	yes					
PRIORITY_ARRAY	yes		yes			
RELINQUISH_DEFAULT	yes		yes			
COV_INCREMENT	no		yes			COV INCREMENT Property
OUTPUT_TYPE *		yes	yes	4001	enumerated	
HAND_STATUS*		yes		3014	Boolean	
HAND_VALUE*		yes		3015	enumerated	

Table 18. Properties of BACnet Analog Output Object

\* Additional properties of an object are saved to maintain the backward compatibility with the older firmware version. In new firmware version, each of the properties has a corresponding BACnet object.

#### 3.5.4.1 PRESENT\_VALUE Property

This property contains voltage value stored in mV or percentage of the Analog Output PWM duty cycle. Output operation mode and Property Units are defined by AO\_CONFIGURATION object.

#### 3.5.4.2 COV INCREMENT Property

In firmware versions above 4.0, MIX and MINI modules support COV (change of value), which means that the module will automatically send the Analog Output value if it changes more than COV Increment property value (For IP modules this value can also be changed in module's web page).

### 3.5.4.3 OUT OF SERVICE Property

For Analog Output OUT OF SERVICE object property is set to true when the output is overridden by USB connection or in module's web page (only in IP version). OUT OF SERVICE is set to false when Present Value property is set by BACnet message.

### 3.5.4.4 STATUS FLAG Property

STATUS FLAG property contains information about the status of object's. This property consists of 4 binary flags. Each flag is described in the table below.

Module Inputs		Results		
AO Potentiometer	Priority Array	Present Value	Analog Output	Status flag property
Auto position	NULL	Default	Default	0000
	ANALOG VALUE	ANALOG VALUE	ANALOG VALUE	
Manual position	NULL	Manual Value	Manual Value	0010
	ANALOG VALUE	Manual Value		

Table 19. STATUS FLAG Property changes

### 3.5.5 AO CONFIGURATION Object (Multistate Value: 17 – 22)

This object contains information about the mode of the Analog Output according to the following table (changing configuration also has an impact on the Analog Output unit property):

Object value	Description	Unit Property
1 (default)	Voltage output 0–10 V	mV
2	PWM 1 Hz	%
3	PWM 10 Hz	%
4	PWM 100 Hz	%
5	PWM 0.1 HZ	%
6	PWM 0.01 Hz	%

Table 20. AO CONFIGURATION Object value list

This configuration is also available in AO Analog Output object as OUTPUT\_TYPE Property 4001.

### 3.5.6 AO HAND\_STATUS Object (Multistate Value: 23 – 26)

This object contains state of Hand Status Operation according to the table below:

Object Value	Description
1	AUTO
2	HAND_ON

*Table 21. AO HAND\_STATUS Object value list*

This information is also available in AO Analog Output object as HAND\_STATUS Property 3014.

**WARNING!** This object is present only in MINI 4U4A-H and 4U4A-H-IP modules.

### **3.5.7 AO HAND\_VALUE Object (Analog Value: 22 – 25)**

This object contains percentage value (0%-100%) of Hand. This information is also available in AO Analog Output object as HAND\_VALUE Property 3015.

**WARNING!** This object is present only available in MINI 4U4A-H and 4U4A-H-IP modules.

### 3.6 Digital Output relay connections

#### 3.6.1 Connecting a solenoid valve to the Digital Output

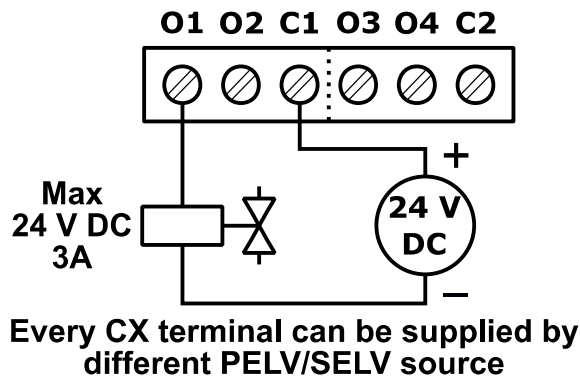

Figure 25. Connection of solenoid valve to DO for MIX38 and MIX38-IP

#### 3.6.2 Connecting a resistive load to the Digital Output

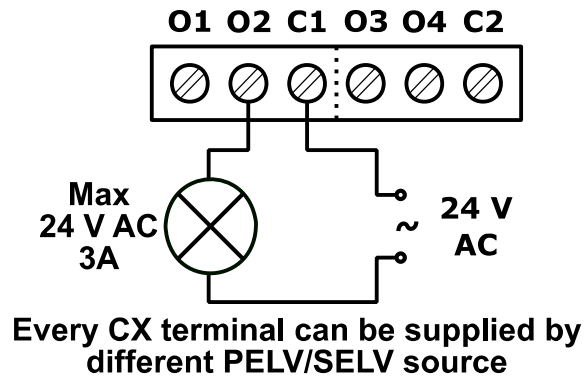

Figure 26. Connection of the resistive load to DO for MIX38 and MIX38-IP

#### 3.6.3 Connecting an inductive load to the Digital Output

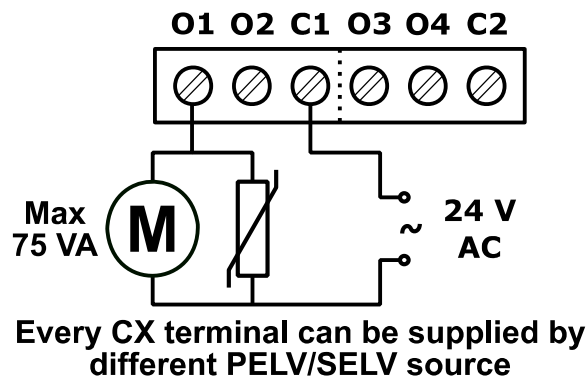

Figure 27. Connection of the inductive load to DO for MIX38 and MIX38-IP

## 3.7 Digital Output BACnet objects

### 3.7.1 BO - Digital Output object description

Each of the Digital Outputs of all types of modules is represented on the BACnet network as BACnet Binary Output Object with the following properties:

Dynamically Creatable: No, Dynamically Deletable: No

Property Name	Required	Proprietary	Writeable	Property ID	Data Type	Description
OBJECT_IDENTIFIER	yes					from BO:0 to BO:12
OBJECT_NAME	yes					BO-x
OBJECT_TYPE	yes					
PRESENT_VALUE	yes		yes			PRESENT_VALUE Property
STATUS_FLAGS	yes					STATUS FLAG Property
EVENT_STATE	yes					
OUT_OF_SERVICE	yes		yes			OUT OF SERVICE Property
POLARITY	yes					
PRIORITY_ARRAY	yes		yes			
RELINQUISH_DEFAULT	yes		yes			
HAND_STATUS *		Yes		3014	enumerated	

Table 22. Properties of BACnet Digital Output Object

\* Additional properties of an object are saved to maintain the backward compatibility with the older firmware version. In the new firmware version, each property has corresponding BACnet object.

#### 3.7.1.1 PRESENT\_VALUE Property

This property contains the actual value of the Digital Output. If DO is in Hand Mode, the actual value of DO is stored in both PRESENT VALUE property and HAND\_STATUS object.

#### 3.7.1.2 Digital Output COV

In firmware versions above 4.0, MIX and MINI modules support COV (change of value). It means that the module will automatically send the Digital Output value with every change.

### 3.7.1.3 STATUS FLAG Property

Status Flag property contains information about the status of the object. This property consists of 4 binary flags. Each flag is described in the table below.

Module Input		Results		
DO Switch	Priority Array	Present Value	Digital Output	Status flag property
Auto position	NULL	Default	Default	0000
	BINARY VALUE	BINARY VALUE	BINARY VALUE	
Manual position ON	NULL	TRUE	ON	0010
	BINARY VALUE			
Manual position OFF	NULL	FALSE	OFF	0010
	BINARY VALUE			

Table 23. Operation of STATUS FLAG Property

### 3.7.1.4 OUT OF SERVICE Property

For Digital Outputs object OUT OF SERVICE property is set to true when output is overridden by USB connection or from module web page (only in IP version). In that case OUT OF SERVICE is set to false, when Present Value property is set by BACnet message.

## 3.7.2 HAND\_STATUS Object (Multistate Value: 23 – 26)

This property is stores information about the status of Hand Operation Switch and as well the status of DO in Hand Mode, according to the table below:

Value of Hand status	Status Description
1	AUTO-OUT=OFF
2	AUTO-OUT=ON
3	HAND-OUT=OFF
4	HAND-OUT=ON

Table 24. DO HAND\_STATUS Object value list

### 3.8 Triac Outputs (TO) connections

#### 3.8.1 Connecting a solenoid valve to the Triac Output

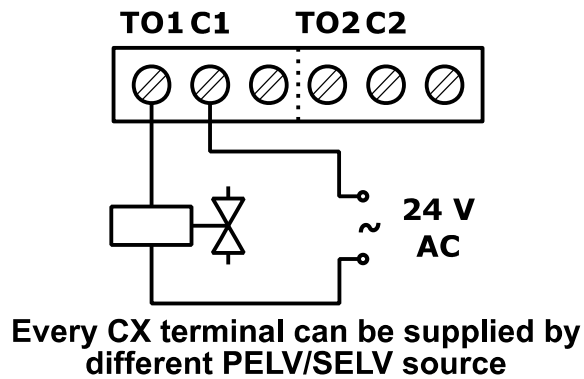

Figure 14. Connection of the solenoid valve to TO for 4TO-H and 4TO-H-IP

#### 3.8.2 Connecting a resistive load to the Triac Output

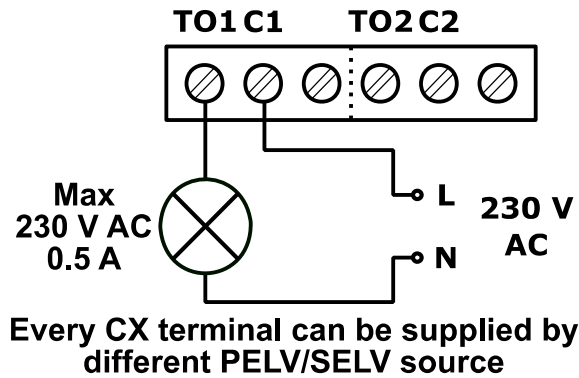

Figure 15. Connection of the resistive load to TO for 4TO-H and 4TO-H-IP



## 3.9 Triac Outputs (TO) BACnet objects

### 3.9.1 TO - Triac Output object description (Binary Output: 0 – 3)

This object is designed to serve the Triac Output in DIGITAL WORKING mode. BACnet Triac Output Object has got the following properties:

Dynamically Creatable: No, Dynamically Deletable: No

Property Name	Required	Proprietary	Writeable	Property ID	Data Type	Description
OBJECT_IDENTIFIER	yes					from BO:0 to BO:3
OBJECT_NAME	yes					TO-x
OBJECT_TYPE	yes					
PRESENT_VALUE	yes		yes			PRESENT_VALUE Property
STATUS_FLAGS	yes					STATUS FLAG Property
EVENT_STATE	yes					
OUT_OF_SERVICE	yes		yes			OUT OF SERVICE Property
POLARITY	yes					
PRIORITY_ARRAY	yes		yes			
RELINQUISH_DEFAULT	yes		yes			

Table 25. Properties of BACnet Triac TO Output Object

#### 3.9.1.1 PRESENT\_VALUE Property

Information on the actual state of Triac Output is stored in the Present Value Property.

**Note:** If TO is in Hand Mode, the actual value of TO is stored in the HAND\_STATUS object.

#### 3.9.1.2 COV INCREMENT Property

In firmware version above 4.0 MIX and MINI modules support COV (change of value), which means that module will automatically send Analog Output value if the value changes more than COV Increment property value.

#### 3.9.1.3 OUT OF SERVICE Property

For Triac Output object OUT OF SERVICE property is set to true when the output is overridden by a USB connection or from module web page (only in IP version). In that case OUT OF SERVICE is set to false value when the Present Value property is set by BACnet message.

OUT OF SERVICE property is also set when Triac Output configuration is set to PWM mode.

### 3.9.1.4 STATUS FLAG Property

Status Flag property contains information about the status of an object status. This property consists of 4 binary flags. Each flag is described in the table below.

Module Input		Results		
TO Switch	Priority Array	Present Value	Digital Output	Status flag property
Auto position	NULL	Default	Default	0000
	BINARY VALUE	BINARY VALUE	BINARY VALUE	
Manual position ON	null	TRUE	ON	0010
	ON			
Manual position OFF	null	FALSE	OFF	0010
	OFF			

Table 26. STATUS FLAG Property changes

### 3.9.2 TO PWM VALUE - Triac PWM object description (Analog Output: 0 - 3)

This object is designed to serve the Triac Output in PWM mode. BACnet PWM VALUE Object has got the following properties:

Dynamically Creatable: No, Dynamically Deletable: No

Property Name	Required	Proprietary	Writable	Property ID	Data Type	Description
OBJECT_IDENTIFIER	yes					from AO:0 to AO:3
OBJECT_NAME	yes					TO-x PWM VALUE
OBJECT_TYPE	Yes					
PRESENT_VALUE	Yes		yes			PRESENT_VALUE Property
STATUS_FLAGS	Yes					STATUS FLAG Property
EVENT_STATE	Yes					
OUT_OF_SERVICE	Yes		yes			OUT OF SERVICE Property
UNITS	Yes					
PRIORITY_ARRAY	Yes		yes			
RELINQUISH_DEFAULT	Yes		yes			
COV_INCREMENT	no		yes			This property stores percentage value of PWM output duty cycle. Output operation mode is defined by TO_CONFIGURATION object. COV_INCREMENT Property
OUTPUT_TYPE *		yes	yes	4001	enumerated	
HAND_STATUS *		yes		3014	Boolean	
HAND_VALUE *		yes		3015	enumerated	

Table 27. Properties of BACnet PWM\_VALUE Object

\* Additional properties of an object are saved to maintain the backward compatibility with the older firmware version. In a new firmware version, each property has a corresponding BACnet object.

### 3.9.2.1 PRESENT\_VALUE Property

This property stores percentage value of PWM output duty cycle. Output operation mode is defined by TO\_CONFIGURATION object.

### 3.9.2.2 COV INCREMENT Property

In firmware version above 4.0, MIX and MINI modules support COV (change of value). It means that the module will automatically send the PWM\_VALUE value if it changes more than COV Increment property value.

### 3.9.2.3 OUT OF SERVICE Property

For PWM Outputs object OUT OF SERVICE property is set to true when the output is overridden by a USB connection or from module web page (only in IP version). In that case OUT OF SERVICE is set to false when the Present Value property is set by a BACnet message. OUT OF SERVICE property is also set true when the Triac Output configuration is set to the Digital Output mode.

### 3.9.2.4 STATUS FLAG Property

Status Flag property contains information about the status of an object. This property consists of 4 binary flags. Each of the flags is described in the table below.

Module Input		Results		
TO Switch	Priority Array	Present Value	Digital Output	Status flag property
Auto position	NULL	Default	Default	0000
	DUTY VALUE	DUTY VALUE	ON/OFF	
Manual position ON	NULL	100%	ON	0010
	DUTY VALUE			
Manual position OFF	NULL	0%	OFF	0010
	DUTY VALUE			

Table 28. STATUS FLAG Property changes

### 3.9.3 HAND\_STATUS Object (Multistate Value: 23 – 26)

Hand Status Object stores the status of Hand Operation Switch and the status of TO in Hand Mode according to the table below:

Value of Hand status	Status Description
1	AUTO-OUT=OFF
2	AUTO-OUT=ON
3	HAND-OUT=OFF
4	HAND-OUT=ON

Table 29. TO HAND\_STATUS Object value list

### 3.9.4 TO CONFIGURATION Object (Multistate Value: 17 – 22)

This object contains information about the mode of the Triac Output according to the following table:

Property value	Description
1 (default)	Digital Output
2	PWM 1 Hz
3	PWM 10 Hz
4	PWM 0.1 HZ
5	PWM 0.01Hz

Table 30. TO CONFIGURATION Object value list

This configuration is also available in PWM VALUE object as OUTPUT\_TYPE Property 4001

### 3.10 Special application modes for 4I4O-H, 4I4O-H-IP, 4U4O-H, and 4U4O-H-IP

4I4O-H, 4I4O-H-IP, 4U4O-H, 4U4O-H-IP modules have simple built-in applications which can be used to control building devices. These applications control Digital Output states according to the signals on Digital input. Relation between Inputs and Outputs is shown in the table below and it cannot be changed.

Digital Input	Digital Output
D11	DO1
D12	DO2
D13	DO3
D14	DO4

Table 31. Built-in application determining the relation between input and output

The Digital Inputs in 4I4O-H, 4I4O-H-IP, 4U4O-H, 4U4O-H-IP modules can be set to work in different modes. There are dedicated objects for input mode (Multistate value 27-30), time parameters (Analog Value 26-29), setpoints for heating/cooling modes (Analog Value 30-33 ;4U4O-H and 4U4O-H-IP only) and for differential value in heating/cooling modes (Analog Value 34-37 ;4U4O-H and 4U4O-H-IP only).

### 3.10.1 INPUT MODE Object (Multistate Value: 27 – 30)

This object contains information about the operating mode of the module. Available modes and Multistate object values are shown in the table below:

Value	OPERATING MODE
0	Ordinary IO(def)
1	Monostable Relay
2	Bistable Relay
3	Time Relay NO [ms]
4	Time Relay NC [ms]
5	Time Relay NO [s]
6	Time Relay NC [s]
7	Input Forwarding
8	Heating (4U4O-H and 4U4O-H-IP only)
9	Cooling (4U4O-H and 4U4O-H-IP only)

Table 32. INPUT\_MODE Object value list

The operating mode can be changed by entering the right value into the Input Mode object.

Special modes are initialized after 3 seconds from the power-up or restart of the module (the time value needed to stabilize the operation of the analog transmitter). Each Input mode change sets corresponding Output to the default state and resets the timer (used in Time-based modes).

#### 3.10.1.1 Ordinary IO

Inputs and outputs operate as standard IO; inputs and outputs are not related with each other.

#### 3.10.1.2 Monostable Relay

In this mode, the Digital Output reflects the corresponding state of the Digital Input. The action of monostable relay can be executed remotely by changing the relevant COMMAND Object. The outputs can be also overwritten by DIGITAL OUTPUT Object, which allows for controlling remotely from BMS.

#### 3.10.1.3 Bistable relay

In this mode, only the rising edge on the Digital Input changes the output state. The action of bistable relay can be executed remotely by changing the relevant COMMAND Object. Outputs can be also overwritten by DIGITAL OUTPUT Object, which allows for remote control from BMS.

#### 3.10.1.4 Time Relay NO [ms]

In this mode, when the output value is false, the rising edge on the Digital Input sets the

output to true. Every falling edge on the Digital Input restarts the counter which means that the output will stay in true value for a time defined in MODE TIME Object (expressed in milliseconds), counting from the last falling edge of Digital Input. The action of time relay can be executed remotely by changing state from false to true in relevant COMMAND Object. The outputs can be also overwritten by DIGITAL OUTPUT Object module, which allows remote control from BMS.

### **3.10.1.5 Time Relay NC [ms]**

In this mode, when the output value is false, the falling edge on Digital Input sets the output to true value. Every rising edge on Digital Input starts the counter from the beginning, which means that the output will stay in true value for a time defined in MODE TIME Object (expressed in milliseconds), counting from the last rising edge of Digital Input. The action of time relay can be executed remotely by changing state from false to true in the relevant COMMAND Object. The outputs can be also overwritten by DIGITAL OUTPUT Object module, which allows for remote control from BMS.

### **3.10.1.6 Time Relay NO [s]**

In this mode, when the output value is false, the rising edge on Digital Input sets the output to true. Every falling edge on Digital Input restarts the counter which means that the output will stay in true value for a time defined in MODE TIME Object (expressed in seconds), counting from the last falling edge of Digital Input. The action of the time relay can be executed remotely by changing state from false to true in the relevant COMMAND Object. The outputs can be also overwritten by DIGITAL OUTPUT Object module, which allows remote control from BMS.

### **3.10.1.7 Time Relay NC [s]**

In this mode, when the output value is false, the falling edge on the Digital Input sets the output to true. Every rising edge on Digital Input restarts the counter which means that the output will stay in true value for a time defined in MODE TIME Object (expressed in seconds), counting from the last rising edge of the Digital Input. The action of time relay can be executed remotely by changing state from false to true in relevant COMMAND Object. The outputs can be also overwritten by DIGITAL OUTPUT Object module, which allows for remote control from BMS.

### **3.10.1.8 Input Forwarding**

In this mode, any signal from the input is transferred directly to the assigned output without any modifications. Operation in the input forwarding mode can be stopped by Block Input function (see [Blocking Object](#)).

### **3.10.1.9 Heating mode (4U40-H and 4U40-H-IP only)**

In this mode, the output is controlled as a typical thermostat, basing on Setpoint Object and

Control value (Input value) with differential parameter defined in Differential Object. The output signal works in 2 states: low and high.

When the Control value is less than or equals to the difference between the Setpoint Object and the Differential Object, the output is in the low state.

When the Control value is greater than or equals to the sum of Setpoint Object and Differential Object, the output is in the high state.

Output in the low state:

Control value  $\geq$  Setpoint + Differential

Output in the high state:

Control value  $\leq$  Setpoint – Differential

Heating mode algorithm is shown in the chart below:

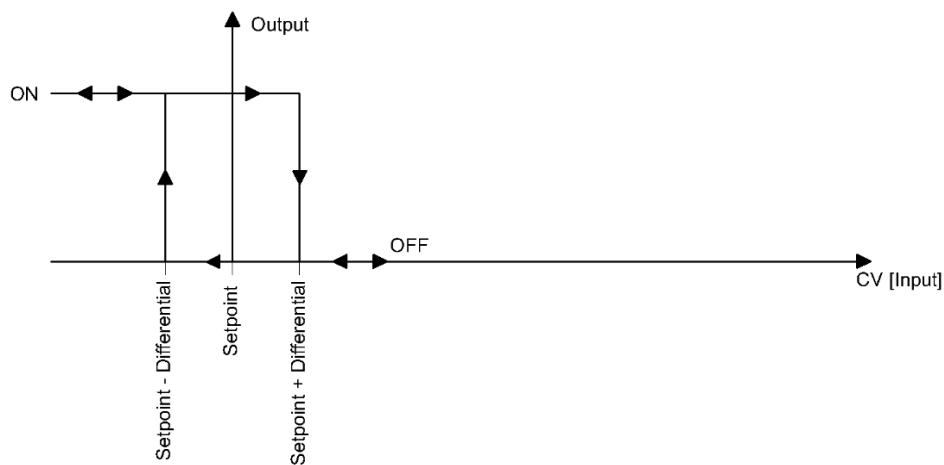

Figure 30. Operation of the heating mode algorithm

**WARNING!** In case when the temperature sensor fails (when it is disconnected or shorted) the heating mode does not work and the output remains in the false state.

### 3.10.1.10 Cooling mode (4U40-H and 4U40-H-IP only)

In this mode, the output is controlled as a typical thermostat, basing on the Setpoint Object and Control value (Input signal) with differential parameter defined in Differential Object.

The output signal works in 2 states - low and high.

When the Control value is less than or equals to the difference between the Setpoint Object and Differential Object, the output is in the low state.

When the Control value is greater than or equals to sum of the Setpoint Object and Differential Object, the output is in the high state.

Output in the low state:

Control value  $\leq$  Setpoint – Differential

Output in the high state:

Control value  $\geq$  Setpoint + Differential

Cooling mode algorithm is shown in the chart below:



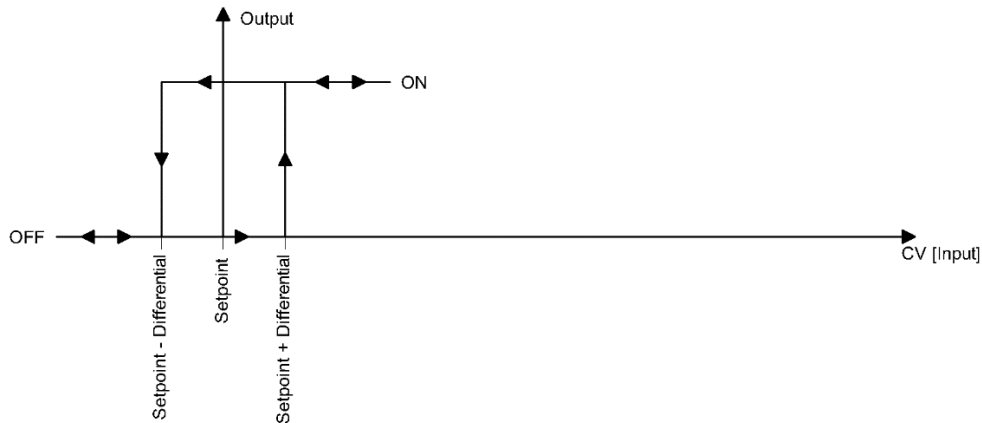

Figure 31. Operation of the cooling mode algorithm

**WARNING!** In case when the temperature sensor fails (when it is disconnected or shorted), the heating mode does not work and the output remains in the false state.

### 3.10.2 MODE TIME Object (Analog Value: 26 – 29)

This object contains the time value for TIME RELAY modes. The time unit depends on selected mode: [milliseconds] or [seconds].

### 3.10.3 COMMAND Object (Binary Value: 12 – 15)

The module includes special COMMAND Objects. The command objects are used for remotely execute action (simulate light switch/PIR). The action is executed by changing the state of the object from false to true. All special application modes can be executed except for Input Forwarding, Heating and Cooling modes.

### 3.10.4 BLOCKING Object (Binary Value: 8 – 11)

The BLOCKING objects are used to block physical input signals from the control logic (all modes excluding heating/cooling mode). By setting true value on the relevant object, the module blocks input and no action will be executed. Setting false value restores normal operation. The block input function does not work when the heating/cooling input mode is set.

### 3.10.5 SETPOINT Object (Analog Value: 30 – 33)

The SETPOINT objects contain values which are used in heating/cooling modes (4U4O-H and 4U4O-H-IP only) as the setpoints for heating/cooling control algorithm. The default Setpoint value is 21. (read more in [Heating mode](#), [Cooling mode](#)).

### 3.10.6 DIFFERENTIAL Object (Analog Value: 34 – 37)

The DIFFERENTIAL objects contain values which are used in heating/cooling modes (4U4O-H and 4U4O-H-IP only) as the differential for heating/cooling control algorithm. Setpoint Objects and Differential Objects create a deadband of the Control values which has no influence on output.

*Deadband = (Setpoint – Differential, Setpoint + Differential)*

The default Differential value is 1. (read more in [Heating mode](#), [Cooling mode](#)).

## 5 WEB Configuration - IP version only

### 5.1 Web server access

All IP version modules have a built-in web server, which allows for showing the status of the module and for changing the configuration.

To access the web server, open a browser and enter the IP address of the module and the default address for a new module is **192.168.1.123**. Please use the following default credentials:

Username: **admin**

Password: 1000

### 5.2 Device page

This page contains information about the device and its technical specification. Basic Information section includes information about the type of the module, its firmware version and uptime. Device Specification includes information about: Power Supply, Inputs/Outputs parameters, Interfaces, and mechanical parameters.

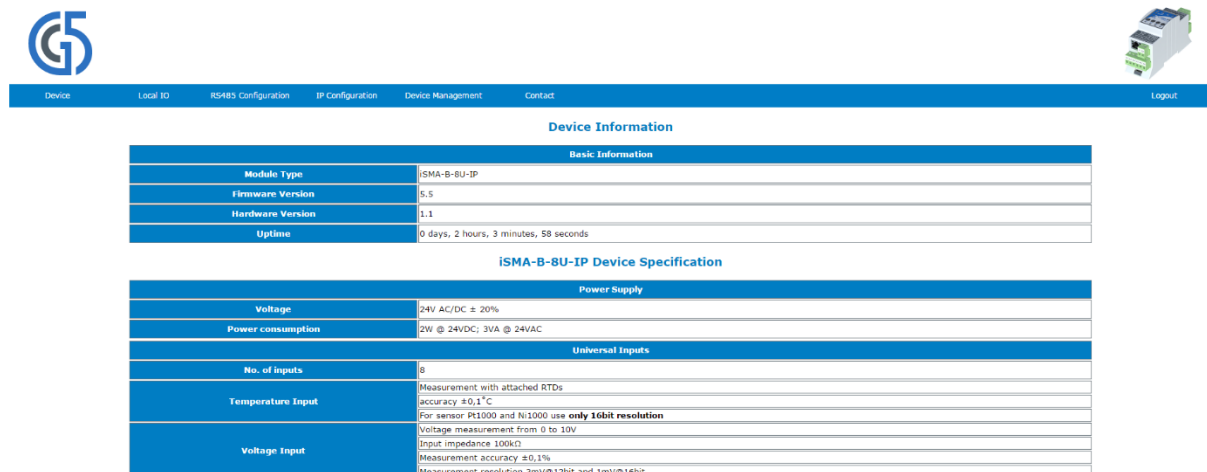

The screenshot shows the web interface for the 8U-IP device. It features a navigation menu at the top with options: Device, Local ID, RS485 Configuration, IP Configuration, Device Management, Contact, and Logout. The main content area is titled "Device Information" and is divided into two sections: "Basic Information" and "ISMA-B-8U-IP Device Specification".

Basic Information	
Module Type	ISMA-B-8U-IP
Firmware Version	5.5
Hardware Version	1.1
Uptime	0 days, 2 hours, 3 minutes, 58 seconds

ISMA-B-8U-IP Device Specification	
Power Supply	
Voltage	24V AC/DC ± 20%
Power consumption	2W @ 24VDC; 3VA @ 24VAC
Universal Inputs	
No. of inputs	8
Temperature Input	Measurement with attached RTDs accuracy ±0.1°C For sensor Pt1000 and Ni1000 use <b>only 16bit resolution</b>
Voltage Input	Voltage measurement from 0 to 10V Input impedance 100kΩ Measurement accuracy ±0.1% Measurement resolution 3mV@12bit and 1mV@16bit

Figure 32. 8U-IP Device page

## 5.3 Local I/O status and configuration

### 5.3.1 Universal Inputs

This page allows for entering the configuration parameters and showing the actual value of the Universal Inputs. To open this page, please navigate to Local IO tab and choose Universal Inputs from the submenu.

Input	Type	Resolution	UI Flag	Disable Voltage Measure	L.P. Filter Constant	Resistance	Temperature	Voltage	BACnet COV Increment
Universal Input 1	Temperature 10k4A1 NTC B=3695K	16 Bit	<input type="checkbox"/>	<input checked="" type="checkbox"/>	1	100000 Ω	-3276.8 °C	0 mV	1.0
Universal Input 2	Temperature 10k3A1 NTC B=3975K	16 Bit	<input type="checkbox"/>	<input checked="" type="checkbox"/>	1	100000 Ω	-3276.8 °C	0 mV	1.0
Universal Input 3	Resistance Input	12 Bit	<input type="checkbox"/>	<input checked="" type="checkbox"/>	0	100000.0 Ω	0.0 °C	0 mV	1.0
Universal Input 4	Resistance Input	12 Bit	<input type="checkbox"/>	<input checked="" type="checkbox"/>	0	100000.0 Ω	0.0 °C	0 mV	1.0
Universal Input 5	Resistance Input	12 Bit	<input type="checkbox"/>	<input checked="" type="checkbox"/>	0	100000.0 Ω	0.0 °C	0 mV	1.0
Universal Input 6	Resistance Input	12 Bit	<input type="checkbox"/>	<input checked="" type="checkbox"/>	0	100000.0 Ω	0.0 °C	0 mV	1.0
Universal Input 7	Resistance Input	12 Bit	<input type="checkbox"/>	<input checked="" type="checkbox"/>	0	100000.0 Ω	0.0 °C	0 mV	1.0
Universal Input 8	Resistance Input	12 Bit	<input type="checkbox"/>	<input checked="" type="checkbox"/>	0	100000.0 Ω	0.0 °C	0 mV	1.0

Figure 33. 8U-IP Universal Inputs page

Input	Type
Universal Input 1	Temperature 10k3A1 NTC B=3975K
Universal Input 2	Disabled Resistance Measurement
Universal Input 3	Temperature 10k3A1 NTC B=3975K
Universal Input 4	Temperature 10k4A1 NTC B=3695K
Universal Input 5	Temperature 10k NTC B=3435K Carel
Universal Input 6	Temperature 20k6A1 NTC B=4262K
Universal Input 7	Temperature 2.2k3A1 NTC B=3975K
Universal Input 8	Temperature 3k3A1 NTC B=3975K
Universal Input 9	Temperature 30k6A1 NTC B=4262K
Universal Input 10	Temperature SIE1
Universal Input 11	Temperature TAC1
Universal Input 12	Temperature SAT1
Universal Input 13	Temperature PT1000
Universal Input 14	Temperature NI1000
Universal Input 15	Resistance Input

Figure 34. Types of sensors

Universal Input table contains the following fields:

- **Sensor type** (Read&Write) allows for setting a different type of sensor
- **Resolution** (Read&Write), resolution measurement 12-bit/16-bit (**for PT1000 and NI1000 sensors please use 16-bit resolution**)
- **UI Flag** (Read Only), status of UI configured as dry contact input
- **Disable Voltage Measurement** (Read&Write), disables voltage measuring resistance measurement only
- **L.P. Filter Constant** (Read&Write), value of time constant for low pass filter in seconds. Valid values must be between 0 and 60 seconds (default 2s). Setting value 0 will disable the filter
- **Resistance** (Read Only), in range from 0 to 1000k [Ω]

- **Temperature** (Read Only), in Celsius with the accuracy of 1 degree [°C]
- **Voltage** (Read Only) in millivolts [mV]
- **BACnet COV Increment** (Read&Write) change of state sending threshold value

**WARNING!** To save the changes, please use the “Submit” button.

### 5.3.2 Configuration of special application modes

This page allows for entering the configuration parameters and showing the actual value of Special application modes. To open this page, please navigate to Local IO tab and choose Universal Inputs from the submenu.

Input	Type	Resolution	UI Flag	Disable Voltage Measure	L.P. Filter Constant	Resistance	Temperature	Voltage	BACnet COV Increment
Universal Input 1	Temperature 10k3A1 NTC B=3975K	12 Bit	<input type="checkbox"/>	<input type="checkbox"/>	0	1000000 Ω	-3276.8 °C	0 mV	1.0
Universal Input 2		12 Bit	<input type="checkbox"/>	<input checked="" type="checkbox"/>	0	0 Ω	0.0 °C	0 mV	1.0
Universal Input 3	Temperature 10k3A1 NTC B=3975K	12 Bit	<input type="checkbox"/>	<input type="checkbox"/>	60	1000000 Ω	-3276.8 °C	0 mV	1.0
Universal Input 4	Disabled Resistance Measurement	12 Bit	<input type="checkbox"/>	<input type="checkbox"/>	3	0 Ω	0.0 °C	0 mV	1.0

Input	Block Input	Input Mode	Command	Mode Time	Setpoint	Diff
Universal Input 1	<input type="checkbox"/>	Heating	<input type="checkbox"/>	1000	21.0 °C	0.0 °C
Universal Input 2	<input type="checkbox"/>	Bistable Relay	<input type="checkbox"/>	10	23.0 °C	0.3 °C
Universal Input 3	<input type="checkbox"/>	Bistable Relay	<input type="checkbox"/>	3	25.0 °C	3.0 °C
Universal Input 4	<input type="checkbox"/>	Heating	<input type="checkbox"/>	0	0.0 °C	0.0 °C

Figure 35. 4U40-IP Universal Inputs page

Input	Block Input	Input Mode
Universal Input 1	<input type="checkbox"/>	Ordinary IO
Universal Input 2	<input type="checkbox"/>	Ordinary IO
Universal Input 3	<input type="checkbox"/>	Monostable Relay
Universal Input 4	<input type="checkbox"/>	Bistable Relay
		Time Relay NO [ms]
		Time Relay NC [ms]
		Time Relay NO [s]
		Time Relay NC [s]
		Input Forwarding
		Heating
		Cooling

Figure 36. Special application modes

Special Modes Configuration table contains the following fields:

- **Block Input** (Read&Write) allows for blocking a particular input (except for heating/cooling modes)
- **Input Mode** (Read&Write), allows for selecting the Special Application Mode for a particular input (Ordinary IO in default)
- **Command** (Read & Write), execution of the Special Application Modes (except for input forwarding, heating/cooling modes)
- **Mode Time** (Read & Write), time base for time relay application modes (the unit depends on the selected mode: [ms] or [s])
- **Setpoint** (Read&Write, 4U40-H-IP only), setpoint value for heating/cooling modes  
In default 0.

- **Differential** (Read&Write, 4U4O-H-IP only), differential value for heating/cooling modes.  
In default 0.

**WARNING!** To save the changes, please use the “Submit” button.

### 5.3.3 Digital Inputs

This page allows for entering the configuration parameters and showing the actual value of the Digital Inputs. To open this page, please navigate to Local IO tab and choose Digital Inputs from the submenu.

Input	State	Reset Flag	Counter State	Counter State To Set
Digital Input 1	<input type="checkbox"/>	<input type="checkbox"/>	13	13
Digital Input 2	<input type="checkbox"/>	<input type="checkbox"/>	2	2
Digital Input 3	<input type="checkbox"/>	<input type="checkbox"/>	2	2
Digital Input 4	<input type="checkbox"/>	<input type="checkbox"/>	2	2
Digital Input 5	<input type="checkbox"/>	<input type="checkbox"/>	2	2
Digital Input 6	<input type="checkbox"/>	<input type="checkbox"/>	2	2
Digital Input 7	<input type="checkbox"/>	<input type="checkbox"/>	2	2
Digital Input 8	<input type="checkbox"/>	<input type="checkbox"/>	2	2
Digital Input 9	<input type="checkbox"/>	<input type="checkbox"/>	2	2
Digital Input 10	<input type="checkbox"/>	<input type="checkbox"/>	2	2
Digital Input 11	<input type="checkbox"/>	<input type="checkbox"/>	2	2
Digital Input 12	<input type="checkbox"/>	<input type="checkbox"/>	2	2

Figure 37. MIX38-IP Digital Inputs page

Digital Input table contains the following fields:

- **State** (Read Only), actual input state
- **Reset Flag** (Read&Write), reset of pulses value (leaving reset active will reset the value of the pulses)
- **Counter State** (Read Only), actual value of pulses saved in EEPROM
- **Counter State To Set** (Read & Write), allows for setting the value of the counter

**WARNING!** To save the changes, please use the “Submit” button.

### 5.3.4 Digital Outputs

This page allows for entering the configuration parameters and showing the actual value of the Digital Outputs. To open this page, please navigate to Local IO tab and choose Digital Outputs from the submenu.

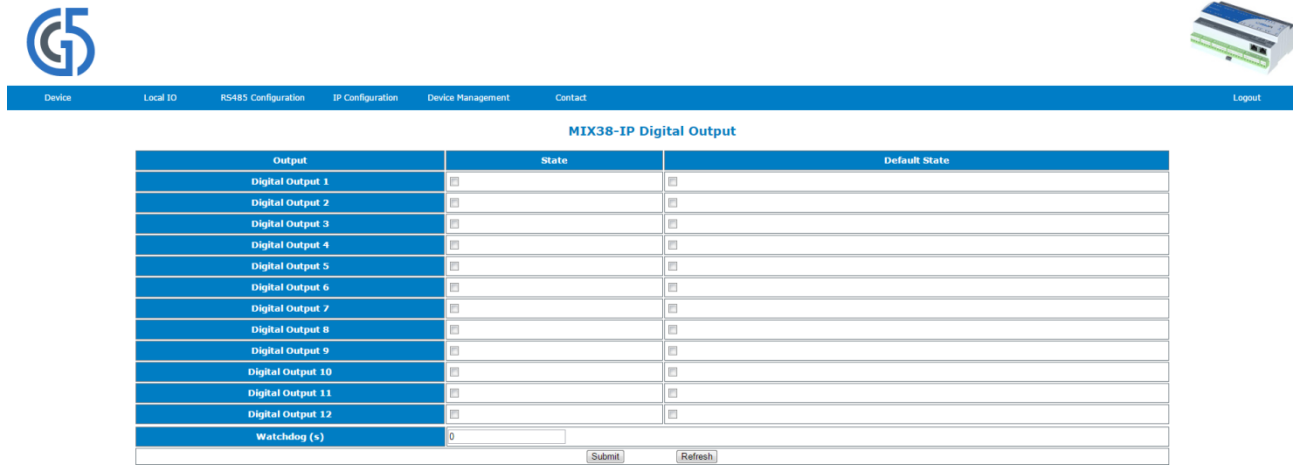

Figure 38. MIX38-IP Digital Outputs page

Digital Outputs contains the following fields:

- **State** (Read&Write), actual state of Digital Output
- **Default State** (Read&Write), output state after power-up and watchdog operation
- **Hand State Output** (Read Only, MINI series only), manually override the status of the switch
- **Watchdog** (Read & Write), device watchdog value in seconds

**WARNING!** To save the changes, please use the “Submit” button.

### 5.3.5 Analog Outputs

This page allows for entering the configuration parameters and showing the actual value of the Analog Outputs. To open this page, please navigate to Local IO tab and choose Analog Outputs from the submenu.

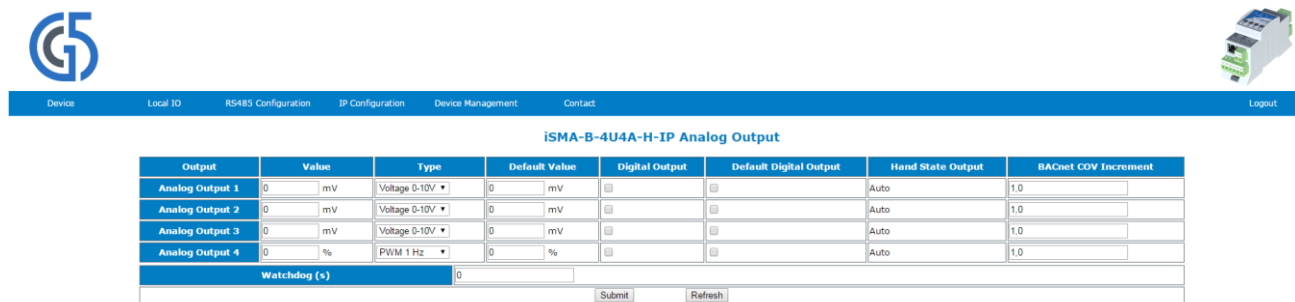

Figure 39. 4U4A-H-IP Analog Outputs page

Analog Outputs table contains the following fields:

- **Value** (Read&Write), actual value of Analog Output in millivolts [mV]

- **Type** (Read&Write), Analog Output operating mode voltage/PWM
- **Default Value** (Read&Write), default output value after power-up and watchdog operation
- **Digital Output** (Read&Write), output status flag for DO mode
- **Default Digital Output** (Read&Write), default output status for DO mode
- **Watchdog** (Read&Write), device watchdog value in seconds
- **Hand State Output** (Read Only, MINI series only), manually overrides the status of the potentiometer
- **BACnet COV Increment** (Read&Write), change of the state sending threshold value

**WARNING!** To save the changes, please use the “Submit” button.

## 5.4 RS485 Configuration

This page allows for entering the configuration parameters and showing the information of controllers RS485 port.

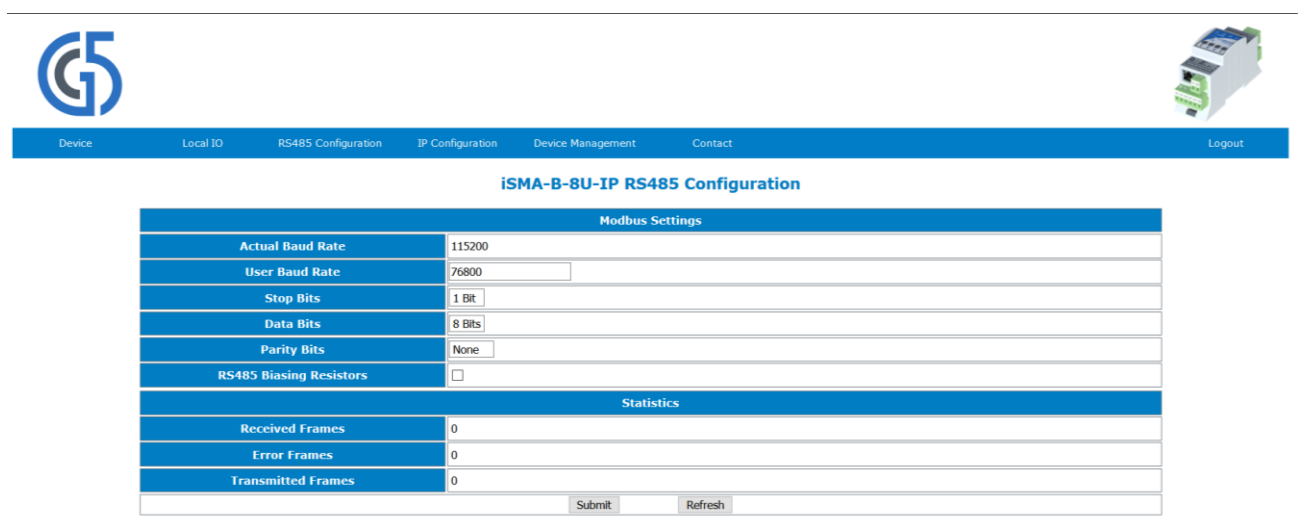

The screenshot shows the web interface for RS485 Configuration. At the top, there is a navigation bar with links: Device, Local IO, RS485 Configuration (active), IP Configuration, Device Management, Contact, and Logout. The main content area is titled "iSMA-B-8U-IP RS485 Configuration". It is divided into two sections: "Modbus Settings" and "Statistics".

Modbus Settings	
Actual Baud Rate	115200
User Baud Rate	76800
Stop Bits	1 Bit
Data Bits	8 Bits
Parity Bits	None
RS485 Biasing Resistors	<input type="checkbox"/>

Statistics	
Received Frames	0
Error Frames	0
Transmitted Frames	0

At the bottom of the form, there are two buttons: "Submit" and "Refresh".

Figure 40. RS485 configuration page

This page allows for setting parameters such as:

- **Baud rate** (Read Only), RS485 baud rate within the range from 2400 up to 115200
- **Modbus Config** (Read Only), Modbus Protocol Type- RTU or ASCII
- **Stop Bits** (Read&Write), number of stop bits (1 or 2)
- **Data Bits** (Read&Write), number of data bits transmitted in a single byte (7 or 8)
- **Parity Bits** (Read&Write), transmission protection as a parity bit added before stop bit (bits)

- **RS485 Biasing Resistors, activation of** the biasing resistors for MINI modules **only** with a hardware version  $\geq 2.0$  (option unavailable in MIX modules)
- **Received Frames (Read Only)**, number of received frames
- **Transmitted Frames (Read Only)**, number of transmitted frames
- **Error Frames (Read Only)**, number of error frames

**WARNING!** To save the changes, please use the “Submit” button.

## 5.5 IP Configuration

This page allows for changing parameters of Ethernet port, Modbus TCP, and BACnet IP.

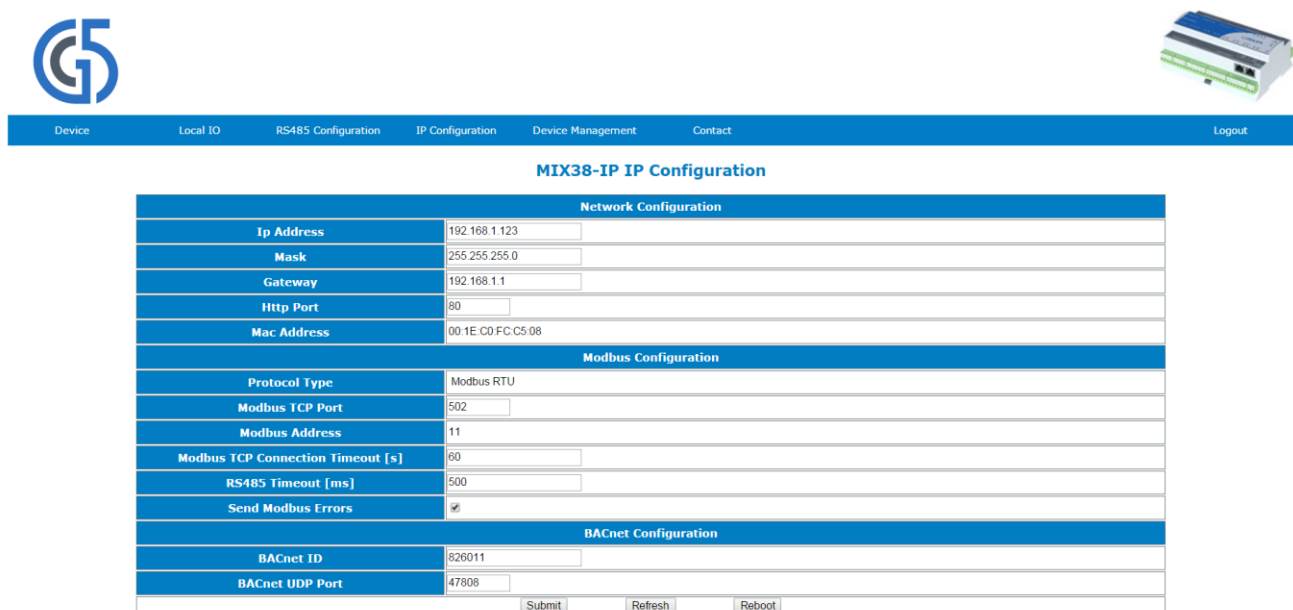

Network Configuration	
Ip Address	192.168.1.123
Mask	255.255.255.0
Gateway	192.168.1.1
Http Port	80
Mac Address	00:1E:C0:FC:C5:08
Modbus Configuration	
Protocol Type	Modbus RTU
Modbus TCP Port	502
Modbus Address	11
Modbus TCP Connection Timeout [s]	60
RS485 Timeout [ms]	500
Send Modbus Errors	<input checked="" type="checkbox"/>
BACnet Configuration	
BACnet ID	826011
BACnet UDP Port	47808
<input type="button" value="Submit"/> <input type="button" value="Refresh"/> <input type="button" value="Reboot"/>	

Figure 41. IP configuration page

This page allows for setting parameters such as:

- **IP Address (Read&Write)**, IP address of the controller Ethernet interface
- **Mask (Read&Write)**, network mask
- **Gateway (Read&Write)**, network default gateway
- **Http Port (Read&Write)**, http port
- **Mac Address (Read Only)**, Ethernet interface MAC address
- **Protocol Type (Read Only)**, Dip Switch protocol selection
- **Modbus TCP Port (Read&Write)**, Modbus TCP port number, default 502
- **Modbus Address (Read Only)**, Modbus device address set by rotary switches
- **Modbus TCP Communication Timeout (Read&Write)**, timeout for TCP/IP messages
- **RS485 Timeout (Read&Write)**, timeout for Modbus RTU/ASCII messages



- **Send Modbus Errors** (Read Only), Enable/Disable sending Modbus error messages
- **BACnet ID** (Read&Write), BACnet ID set by rotary switches, this value can be overridden by the user; once overridden by the user, changing rotary switches will not affect BACnet ID
- **BACnet UDP port** (Read&Write), BACnet IP port

**WARNING!** To save the changes, please first click the “Submit” button and then the “Reboot” button.

## 5.6 Device management

This page allows for changing the password and rebooting the device remotely.



Figure 42. Device management page

Procedure of changing the device password:

- a) enter current device password in field - Current Device Password,
- b) enter the new device password in field - New Device Password,
- c) enter the new device password again in the field - Confirm New Device Password,
- d) to confirm the password change, please click the “Submit” button,
- e) please Logout and Login again using the new password.

**WARNING!** To reset the password to default refer to “Restoring default settings”.

## 5.7 Contact

This page displays information about Manufacture web address and email to technical support.



Figure 43. Contact page view

## 6 BACnet Object Table

BACnet Name	BACnet Type	ID	Access	COV	Description
UI-1	Analog Input	0	RO	Yes	Universal Input current value
UI-2	Analog Input	1	RO	Yes	
UI-3	Analog Input	2	RO	Yes	
UI-4	Analog Input	3	RO	Yes	
UI-5	Analog Input	4	RO	Yes	
UI-6	Analog Input	5	RO	Yes	
UI-7	Analog Input	6	RO	Yes	
UI-8	Analog Input	7	RO	Yes	
AO-1	Analog Output	0	RW	Yes	Analog Output current value
AO-2	Analog Output	1	RW	Yes	
AO-3	Analog Output	2	RW	Yes	
AO-4	Analog Output	3	RW	Yes	
AO-5	Analog Output	4	RW	Yes	
AO-6	Analog Output	5	RW	Yes	
BI-1	Binary Input	0	RO	Yes	Digital Input current value
BI-2	Binary Input	1	RO	Yes	
BI-3	Binary Input	2	RO	Yes	
BI-4	Binary Input	3	RO	Yes	
BI-5	Binary Input	4	RO	Yes	
BI-6	Binary Input	5	RO	Yes	
BI-7	Binary Input	6	RO	Yes	
BI-8	Binary Input	7	RO	Yes	
BI-9	Binary Input	8	RO	Yes	
BI-10	Binary Input	9	RO	Yes	
BI-11	Binary Input	10	RO	Yes	
BI-12	Binary Input	11	RO	Yes	
BO-1	Binary Output	0	RW	Yes	Digital Output current value
BO-2	Binary Output	1	RW	Yes	
BO-3	Binary Output	2	RW	Yes	
BO-4	Binary Output	3	RW	Yes	
BO-5	Binary Output	4	RW	Yes	
BO-6	Binary Output	5	RW	Yes	
BO-7	Binary Output	6	RW	Yes	
BO-8	Binary Output	7	RW	Yes	
BO-9	Binary Output	8	RW	Yes	
BO-10	Binary Output	9	RW	Yes	
BO-11	Binary Output	10	RW	Yes	
BO-12	Binary Output	11	RW	Yes	
UI-1_DRY_CONTACT	Binary Value	0	RO	No	Universal Input Dry Contact Binary Value
UI-2_DRY_CONTACT	Binary Value	1	RO	No	
UI-3_DRY_CONTACT	Binary Value	2	RO	No	
UI-4_DRY_CONTACT	Binary Value	3	RO	No	
UI-5_DRY_CONTACT	Binary Value	4	RO	No	
UI-6_DRY_CONTACT	Binary Value	5	RO	No	
UI-7_DRY_CONTACT	Binary Value	6	RO	No	
UI-8_DRY_CONTACT	Binary Value	7	RO	No	
UP_TIME	Analog Value	0	RO	No	Module working time [s]
WATCHDOG	Analog Value	1	RW	No	Watchdog time value [s] 0 - disable
BI-1_COUNTER	Analog Value	2	RW	No	Digital Input counter value Analog Value BACnet object (The same function is also available using Accumulator)
BI-2_COUNTER	Analog Value	3	RW	No	
BI-3_COUNTER	Analog Value	4	RW	No	
BI-4_COUNTER	Analog Value	5	RW	No	

BACnet Name	BACnet Type	ID	Access	COV	Description
BI-5_COUNTER	Analog Value	6	RW	No	BACnet object)
BI-6_COUNTER	Analog Value	7	RW	No	
BI-7_COUNTER	Analog Value	8	RW	No	
BI-8_COUNTER	Analog Value	9	RW	No	
BI-9_COUNTER	Analog Value	10	RW	No	
BI-10_COUNTER	Analog Value	11	RW	No	
BI-11_COUNTER	Analog Value	12	RW	No	
BI-12_COUNTER	Analog Value	13	RW	No	
UI-1_FILTER	Analog Value	14	RW	No	Universal Input Low Pass filter time value (default value 2s)
UI-2_FILTER	Analog Value	15	RW	No	
UI-3_FILTER	Analog Value	16	RW	No	
UI-4_FILTER	Analog Value	17	RW	No	
UI-5_FILTER	Analog Value	18	RW	No	
UI-6_FILTER	Analog Value	19	RW	No	
UI-7_FILTER	Analog Value	20	RW	No	
UI-8_FILTER	Analog Value	21	RW	No	
AO-1_HAND_VALE	Analog Value	22	RO	No	Analog Output value in hand mode value
AO-2_HAND_VALE	Analog Value	23	RO	No	
AO-3_HAND_VALE	Analog Value	24	RO	No	
AO-4_HAND_VALE	Analog Value	25	RO	No	
UI-1_CONFIGURATION	Multistate Value	1	RW	No	Universal Input configuration: - Voltage - Resistance - Temperature sensor type
UI-2_CONFIGURATION	Multistate Value	2	RW	No	
UI-3_CONFIGURATION	Multistate Value	3	RW	No	
UI-4_CONFIGURATION	Multistate Value	4	RW	No	
UI-5_CONFIGURATION	Multistate Value	5	RW	No	
UI-6_CONFIGURATION	Multistate Value	6	RW	No	
UI-7_CONFIGURATION	Multistate Value	7	RW	No	
UI-8_CONFIGURATION	Multistate Value	8	RW	No	
UI-1_RESOLUTION	Multistate Value	9	RW	No	Universal Input resolution: - 12-bits (default) - 16-bits
UI-2_RESOLUTION	Multistate Value	10	RW	No	
UI-3_RESOLUTION	Multistate Value	11	RW	No	
UI-4_RESOLUTION	Multistate Value	12	RW	No	
UI-5_RESOLUTION	Multistate Value	13	RW	No	
UI-6_RESOLUTION	Multistate Value	14	RW	No	
UI-7_RESOLUTION	Multistate Value	15	RW	No	
UI-8_RESOLUTION	Multistate Value	16	RW	No	
AO-1_CONFIGURATION	Multistate Value	17	RW	No	Analog Output working mode (default mode 0-10 V)
AO-2_CONFIGURATION	Multistate Value	18	RW	No	

BACnet Name	BACnet Type	ID	Access	COV	Description
AO-3_CONFIGURATION	Multistate Value	19	RW	No	
AO-4_CONFIGURATION	Multistate Value	20	RW	No	
AO-5_CONFIGURATION	Multistate Value	21	RW	No	
AO-6_CONFIGURATION	Multistate Value	22	RW	No	
AO-1_HAND_STATUS	Multistate Value	23	RO	No	Analog Output value in hand mode status: HAND / AUTO
AO-2_HAND_STATUS	Multistate Value	24	RO	No	
AO-3_HAND_STATUS	Multistate Value	25	RO	No	
AO-4_HAND_STATUS	Multistate Value	26	RO	No	
BO-1_HAND_STATUS	Multistate Value	23	RO	No	Digital Output value in hand mode status: HAND / AUTO
BO-2_HAND_STATUS	Multistate Value	24	RO	No	
BO-3_HAND_STATUS	Multistate Value	25	RO	No	
BO-4_HAND_STATUS	Multistate Value	26	RO	No	
BIA-1_COUNTER	Accumulator	0	RW	No	Digital Input counter value Accumulator BACnet object (The same function is also available using Analog Value BACnet object)
BIA-2_COUNTER	Accumulator	1	RW	No	
BIA-3_COUNTER	Accumulator	2	RW	No	
BIA-4_COUNTER	Accumulator	3	RW	No	
BIA-5_COUNTER	Accumulator	4	RW	No	
BIA-6_COUNTER	Accumulator	5	RW	No	
BIA-7_COUNTER	Accumulator	6	RW	No	
BIA-8_COUNTER	Accumulator	7	RW	No	
BIA-9_COUNTER	Accumulator	8	RW	No	
BIA-10_COUNTER	Accumulator	9	RW	No	
BIA-11_COUNTER	Accumulator	10	RW	No	
BIA-12_COUNTER	Accumulator	11	RW	No	
For MINI 4TO-H and 4TO-H-IP only					
TO-1	Binary Output	0	RW	Yes	Triac Output current value (In Digital Output operation mode)
TO-2	Binary Output	1	RW	Yes	
TO-3	Binary Output	2	RW	Yes	
TO-4	Binary Output	3	RW	Yes	
TO-1_PWM VALUE	Analog Output	0	RW	Yes	Triac Output current value (In PWM operation mode)
TO-2_PWM VALUE	Analog Output	1	RW	Yes	
TO-3_PWM VALUE	Analog Output	2	RW	Yes	
TO-4_PWM VALUE	Analog Output	3	RW	Yes	
TO-1_CONFIGURATION	Multistate Value	17	RW	No	Triac Output operation mode configuration, options: - Digital Output - PWM
TO-1_CONFIGURATION	Multistate Value	18	RW	No	
TO-1_CONFIGURATION	Multistate Value	19	RW	No	
TO-1_CONFIGURATION	Multistate Value	20	RW	No	
TO-1_HAND_STATUS	Multistate Value	23	RO	No	Triac Output hand mode status
TO-1_HAND_STATUS	Multistate	24	RO	No	

BACnet Name	BACnet Type	ID	Access	COV	Description
	Value				
TO-1_HAND_STATUS	Multistate Value	25	RO	No	
TO-1_HAND_STATUS	Multistate Value	26	RO	No	
For MINI 4I4O-H and 4I4O-H-IP only					
BI-1_INPUT_MODE	Multistate Value	27	RW	No	Ordinary IO (def) Monostable Relay Bistable Relay Time Relay NO [ms] Time Relay NC [ms] Time Relay NO [s] Time Relay NC [s] Input Forwarding (4U4O-H, 4U4O-H-IP only) Heating Cooling
BI-2_INPUT_MODE	Multistate Value	28	RW	No	
BI-3_INPUT_MODE	Multistate Value	29	RW	No	
BI-4_INPUT_MODE	Multistate Value	30	RW	No	
BI-1_MODE_TIME	Analog Value	26	RW	No	Time Value object for Time Relay Mode
BI-2_MODE_TIME	Analog Value	27	RW	No	
BI-3_MODE_TIME	Analog Value	28	RW	No	
BI-4_MODE_TIME	Analog Value	29	RW	No	
BI-1_BLOCK_INPUT	Binary Value	8	RW	No	Digital Input blocking command,
BI-2_BLOCK_INPUT	Binary Value	9	RW	No	
BI-3_BLOCK_INPUT	Binary Value	10	RW	No	
BI-4_BLOCK_INPUT	Binary Value	11	RW	No	
BI-1_COMMAND	Binary Value	12	RW	No	Digital Input remote command,
BI-2_COMMAND	Binary Value	13	RW	No	
BI-3_COMMAND	Binary Value	14	RW	No	
BI-4_COMMAND	Binary Value	15	RW	No	
For MINI 4U4O-H and 4U4O-H-IP only					
BI-1_SETPOINT	Analog Value	30	RW	No	SETPOINT for Heating/Cooling modes Default = 0
BI-2_SETPOINT	Analog Value	31	RW	No	
BI-3_SETPOINT	Analog Value	32	RW	No	
BI-4_SETPOINT	Analog Value	33	RW	No	
BI-1_DIFFERENTIAL	Analog Value	34	RW	No	DIFFERENTIAL for Heating/Cooling modes Default = 0
BI-2_DIFFERENTIAL	Analog Value	35	RW	No	
BI-3_DIFFERENTIAL	Analog Value	36	RW	No	
BI-4_DIFFERENTIAL	Analog Value	37	RW	No	

Table 33. BACNET Object table

## 7 List of supported temperature sensors

No	1	No	2
Sensor $\beta$ coefficient  Manufacturers  $^{\circ}\text{C}$	10K3A1	Sensor $\beta$ coefficient  Manufacturers  $^{\circ}\text{C}$	10K4A1
	3975K		3695K
	Aquatrol, Cylon, Honeywell, Johnson, Satchwell, Seachange		Andover, Delta Controls, Siebe, York
	$\Omega$		$\Omega$
-50	667828	-50	441667
-45	491749	-45	330749
-40	335671	-40	239831
-35	241840	-35	181532
-30	176683	-30	135233
-25	131251	-25	105081
-20	96974	-20	78930
-15	72895	-15	61030
-10	55298	-10	47549
-5	42314	-5	37316
0	32650	0	29490
5	25396	5	23462
10	19904	10	18787
15	15714	15	15136
20	12494	20	12268
25	10000	25	10000
30	8056	30	8197
35	6530	35	6754
40	5325	40	5594
45	4367	45	4656
50	3601	50	3893
55	2985	55	3271
60	2487	60	2760
65	2082	65	2339
70	1751	70	1990
75	1480	75	1700
80	1256	80	1458
85	1070	85	1255
90	916	90	1084
95	787	95	939
100	678	100	817
105	587	105	713

No	1	No	2
110	510	110	624
115	444	115	547
120	388	120	482
125	340	125	426



No Sensor $\beta$ coefficient	3	No Sensor $\beta$ coefficient Manufacturers	4
	10K Carel		20K6A1
	3435K		4262K
-50	329500	°C	$\Omega$
-45	247700	-40	806800
-40	188500	-35	574400
-35	144100	-30	413400
-30	111300	-25	300400
-25	86430	-20	220600
-20	67770	-15	163480
-15	53410	-10	122260
-10	42470	-5	92220
-5	33900	0	70140
0	27280	5	53780
5	22050	10	41540
10	17960	15	32340
15	14690	20	25340
20	12090	25	20000
25	10000	30	15886
30	8313	35	12698
35	6940	40	10212
40	5827	45	8260
45	4912	50	6718
50	4161	55	5494
55	3536	60	4518
60	3020	65	3732
65	2588	70	3098
70	2228	75	2586
75	1924	80	2166
80	1668	85	1823
85	1451	90	1541
90	1266	95	1308
95	1108	100	1114
100	973	105	953
105	857	110	818
110	758	115	704
115	672	120	609
120	597	125	528
125	531		

No Sensor $\beta$ coefficient Manufacturers	5	No Sensor $\beta$ coefficient Manufacturers	6
	2.2K3A1		3K3A1
	3975K		3975K
	Ambiflex, Johnson		Alerton
$^{\circ}\text{C}$	$\Omega$	$^{\circ}\text{C}$	$\Omega$
-50	150395	-50	200348
-45	112994	-45	150524
-40	75593	-40	100701
-35	57691	-35	76853
-30	39789	-30	53005
-25	30814	-25	41048
-20	21839	-20	29092
-15	16416	-15	21868
-10	12453	-10	16589
-5	9529	-5	12694
0	7353	0	9795
5	5719	5	7619
10	4482	10	5971
15	3539	15	4714
20	2814	20	3748
25	2252	25	3000
30	1814	30	2417
35	1471	35	1959
40	1199	40	1598
45	983	45	1310
50	810	50	1080
55	672	55	896
60	560	60	746
65	468	65	625
70	394	70	526
75	333	75	444
80	282	80	377
85	241	85	321
90	206	90	275
95	177	95	236
100	152	100	204
105	132	105	176
110	114	110	153
115	100	115	133
120	88	120	117

No	5	No	6
125	77	125	102

No Sensor $\beta$ coefficient Manufacturers	7	No Sensor Manufacturers $^{\circ}\text{C}$	8
	30K6A1		SIE1
	4262K		Barber Colman, Siebe
$^{\circ}\text{C}$	$\Omega$	$^{\circ}\text{C}$	$\Omega$
		-50	10732
-30	622911	-45	10624
-25	477393	-40	10517
-20	331876	-35	10344
-15	245785	-30	10172
-10	183697	-25	9913
-5	138502	-20	9654
0	105305	-15	9320
5	60713	-10	8933
10	62347	-5	8496
15	48511	0	8044
20	38019	5	7489
25	30000	10	6938
30	23828	15	6370
35	19046	20	5798
40	15317	25	5238
45	12390	30	4696
50	10079	35	4185
55	8243	40	3707
60	6777	45	3271
65	5600	50	2875
70	4650	55	2521
75	3879	60	2206
80	3251	65	1929
85	2737	70	1685
90	2313	75	1472
95	1963	80	1287
100	1672	85	1127
105	1430	90	986
110	1228	95	866
115	1058	100	760
120	915	105	670
125	793	110	590
		115	522
		120	462
		125	410



No Sensor $\beta$ coefficient Manufacturers	9	No Sensor Manufacturers $^{\circ}\text{C}$	10
	TAC1		SAT1
	3500K		Satchwell
$^{\circ}\text{C}$	$\Omega$	$^{\circ}\text{C}$	$\Omega$
-40	39024	-50	9719
-35	29358	-45	9652
-30	22284	-40	9584
-25	17073	-35	9467
-20	13192	-30	9349
-15	10276	-25	9159
-10	8068	-20	8968
-5	6382	-15	8708
0	5085	-10	8396
5	4078	-5	8031
10	3294	0	7614
15	2676	5	7150
20	2188	10	6649
25	1800	15	6121
30	1488	20	5580
35	1237	25	5039
40	1034	30	4513
45	869	35	4012
50	733	40	3545
55	622	45	3117
60	529	50	2730
65	453	55	2386
70	389	60	2082
75	335	65	1816
80	290	70	1585
85	252	75	1385
90	220	80	1213
95	192	85	1064
100	169	90	937
105	149	95	828
110	131	100	734
115	116	105	654
120	103	110	585
125	92	115	525
		120	474
		125	429



No Sensor Manufacturers	16	No Sensor Manufacturers	16
	Pt1000		Pt1000
	Honeywell, Sauter, Serck, Siebe, Cylon		Honeywell, Sauter, Serck, Siebe, Cylon
°C	Ω	°C	Ω
-50	803.1	310	2156.1
-40	842.7	320	2191.5
-30	882.2	330	2226.8
-20	921.6	340	2262.1
-10	960.9	350	2297.2
0	1000.0	360	2332.1
10	1039.0	370	2367.0
20	1077.9	380	2401.8
30	1116.7	390	2436.4
40	1155.4	400	2470.9
50	1194.0		
60	1232.4	<b>No</b>	<b>17</b>
70	1270.8	<b>Sensor</b>	Ni1000
80	1309.0	<b>Manufacturers</b>	Sauter
90	1347.1	<b>°C</b>	<b>Ω</b>
100	1385.1	-50	742.6
110	1422.9	-40	791.3
120	1460.7	-30	841.5
130	1498.3	-20	893.0
140	1535.8	-10	945.8
150	1573.3	0	1000.0
160	1610.5	10	1055.5
170	1647.7	20	1112.4
180	1684.8	30	1170.6
190	1721.7	40	1230.1
200	1758.6	50	1291.1
210	1795.3	60	1353.4
220	1831.9	70	1417.2
230	1868.4	80	1482.5
240	1904.7	90	1549.4
250	1941.0	100	1617.8
260	1977.1	110	1687.9
270	2013.1	120	1759.8
280	2049.0	130	1833.4
290	2084.8	140	1909.0



No	16	No	16
300	2120.5	150	1986.6