

JACE-8000 Controller (12977)

QUICK START INSTALL SHEET

Figure 1 JACE-8000 controller (with one option module).

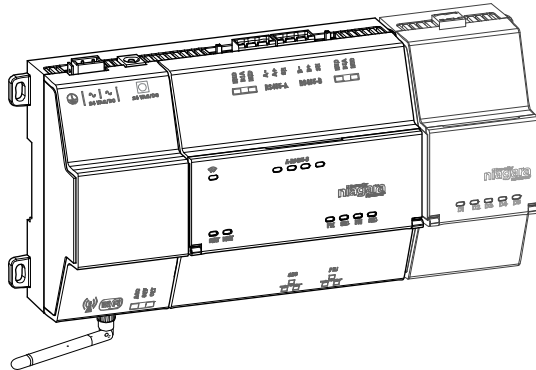

This is a quick-start document for the mounting and wiring of the following products.

Model	Description
JACE-8000 (12977)	DIN-mount, 24Vac/dc powered, Niagara 4@ area controller. See the product data sheet for complete specifications.
WPM24-XXX	Wall-mount, Class 2 universal AC power adapter supplying 24VAC.

NOTE: Niagara 4 is required for any JACE-8000 controller. A maximum of four (4) total option modules are supported. Separate limits may exist in the controller's license, which can further limit options.

See the controller's full *Mounting and Wiring Guide* for complete hardware installation details.

Included in this package

Included in this package you should find the following items:

- JACE-8000 (12977) controller.
- MicroSD card in plastic case. See "Preparation," page 1.
- Coax-mount, dual 2.4/5.8GHz antenna for WiFi, two 3-position RS485 connector plugs, and a grounding wire.
- This JACE-8000 *Controller Quick Start Install Sheet*.

Material and tools required

- One of the following:
 - UL listed, Class 2, 24Vac transformer, rated at minimum of 20VA. A dedicated transformer is required (cannot power additional equipment), or
 - 24Vdc power supply, capable of supplying at least 1A (24W), or
 - WPM24-XXX wall-mount AC power adapter with barrel connector plug.
- DIN rail, type NS35/7.5 (35mm x 7.5mm) and DIN rail end-clips (stop clips), recommended for any installation that includes option modules.
- Suitable tools and fasteners for mounting the unit and any accessories.

Preparation

Before mounting a new controller, you must insert the included microSD flash memory card. Note the card has the unique Niagara identity (host ID) for the unit, set at the factory.

Caution **Disconnect all power** to the controller **before removing or inserting** the microSD card. Otherwise, equipment damage is likely to occur.

Figure 2 MicroSD card location in controller.

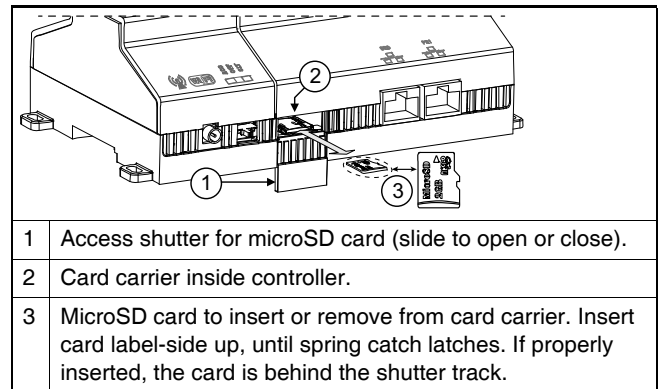

1	Access shutter for microSD card (slide to open or close).
2	Card carrier inside controller.
3	MicroSD card to insert or remove from card carrier. Insert card label-side up, until spring catch latches. If properly inserted, the card is behind the shutter track.

NOTE: Data on the microSD card is encrypted by a special "system password" stored in the controller base. If swapping in a card from a previously configured unit, you must re-enter this same password, using a serial connection to the unit's Debug port.

Precautions

The following are warnings relating to the installation and start-up of the controller.

General precautions

Caution **Remove all power to controller before attaching (plug in) or detaching (unplug) any option module**, to prevent possible equipment damage.

Caution **Removal of the controller's cover is not required.** No configurable or user-serviceable items (such as jumpers or a battery) require cover removal.

Safety precautions

- Warning**
- **Disconnect power before installation or servicing to prevent electrical shock or equipment damage.**
 - **To reduce the risk of fire or electrical shock, install in a controlled environment relatively free of contaminants.**



Mounting

Mount the controller in a location that allows clearance for wiring, servicing, and module removal.

Environmental requirements

NOTE: This product is for **indoor use only**, altitude to 2,000m (6,562 ft.).

Ambient conditions must be within the range of:

- Operating Temperature: -20°C to 60°C (-4°F to 140°F). Storage Temperature: -40°C to 85°C (-40°F to 185°F).
- Relative humidity: 5% to 95% non-condensing. Pollution Degree 3
- Supply (mains) voltage requirements are as follows:
 - Allowable voltage fluctuation to -15%, +10%, Temporary overvoltages +/- 15%.

NOTE: Horizontal mounting is **strongly recommended**, to achieve maximum heat dissipation and meet the operating temperature upper limit. Any other mounting orientation reduces this upper limit.

Mounting on DIN rail

1. Pull the controller's locking clip down.

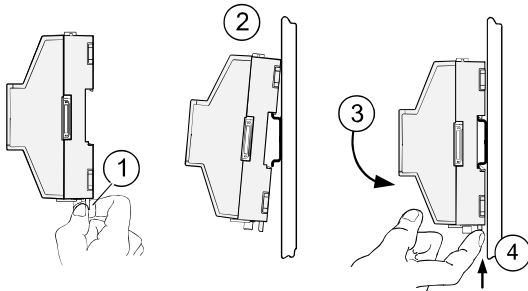

2. Tilt the controller to hook over the DIN rail.
3. Push down and in on the unit, fastening to the rail.
4. Push the locking clip up to secure.
5. Mount any option module onto the DIN rail in the same way.

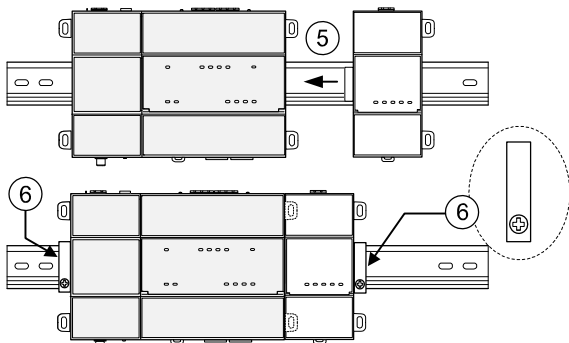

Slide the module firmly into the controller's connector to seat. Repeat for other modules as needed (4 maximum).

6. Secure both ends of the final assembly with DIN rail end-clips provided by the DIN rail vendor.

Wiring

Earth ground and power

Earth grounding provides protection from electrostatic discharge or other forms of EMI.

Figure 3 Earth ground and power options.

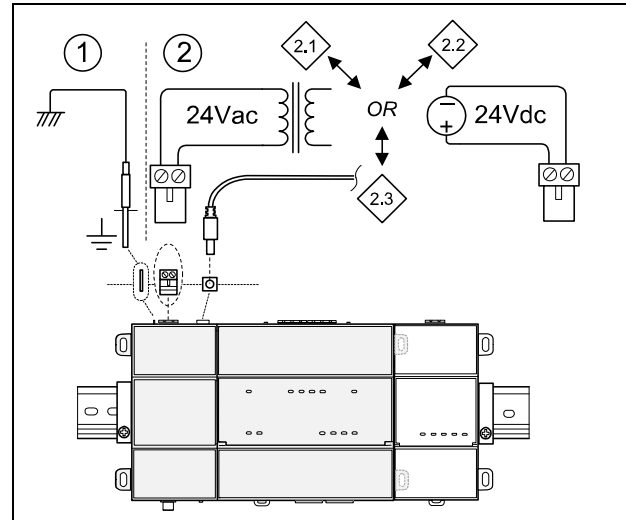

NOTES: Depending on power source used (see [Figure 3](#)):

- **2.1 (AC):** Dedicated 24V transformer required, with neither side of the transformer secondary tied to ground.
- **2.2 (DC):** Polarity is unimportant (uses onboard diode bridge), with neither leg tied to ground.
- **2.3 (Wall-mount AC adapter, WPM24-XXX)** instead of wiring 24V to 2-position connector.

Wiring earth ground and power

Warning Before making power terminations, de-energize the 24V power source. Do not restore power until completing all other mounting and wiring. See **“Power up and initial checkout”** on page 4.

Prerequisite: A nearby earth grounding point.

1. Install the included earth ground wire to the controller's earth ground spade lug, and terminate the other end to a nearby earth ground.
2. Unplug the controller's 2-position power connector plug and terminate the 24V supply source (AC or DC) to the connector. Leave connector unplugged for now.

Communications wiring

Ports for field communications are shown below.

Figure 4 Communications ports on controller.

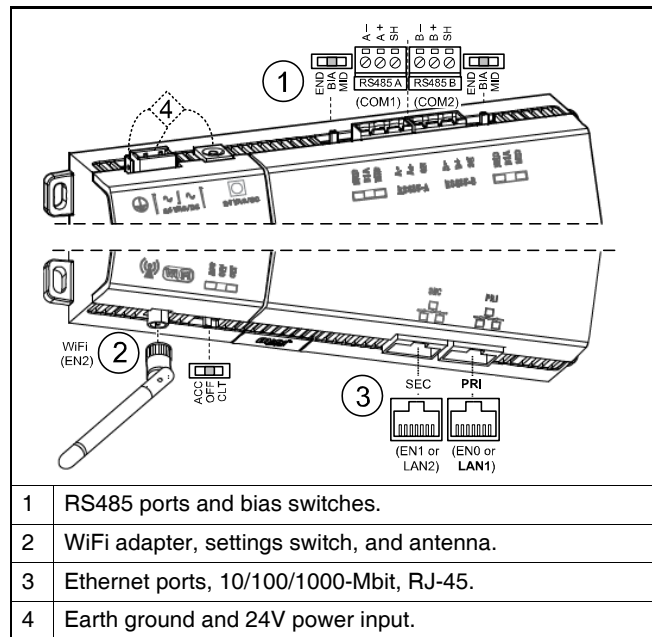

WiFi

An integral WiFi adapter provides wireless connectivity using the IEEE 802.11b/g/n standard, and provides an RP-SMA coax antenna connector.

The WiFi configuration switch sets operation as follows:

- **OFF** - (Default, middle) WiFi adapter is disabled.
- **ACC** - Controller provides operation as a WiFi access point for up to 20 clients.
- **CLT** - Controller operates as a client to an existing 802.11b/g/n router or access point.

Refer to the document *Niagara 4 JACE WiFi Operation - Engineering Notes* for details on WiFi configuration and factory-default IP settings.

RS485 wiring

On the controller's top side, two RS485 ports operate as COM1 and COM2. Each port is capable of up to 115,200 baud, and uses a 3-position, screw terminal connector.

Use shielded, twisted-pair, 18-22 AWG cabling to wire in a continuous multidrop fashion to other RS485 devices: "minus to minus", "plus to plus," and "shield to shield."

Connect the shield wire to earth ground at one end only. The following figure shows example wiring.

Figure 5 RS485 wiring example.

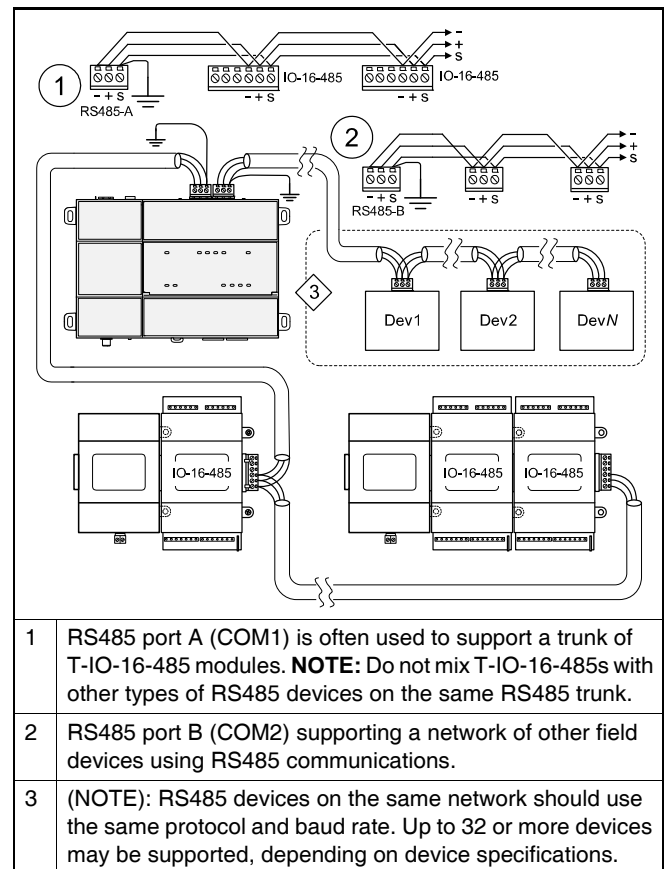

RS485 bias switches — Each RS485 port has an adjacent 3-position biasing switch, with these settings:

- **BIA** - (Default, middle) Controller provides RS485 biasing, but without a termination resistor.
- **END** - Both RS485 biasing and a termination resistor are provided by the controller.
- **MID** - No RS485 biasing or termination resistor is provided by the controller.

Often, adding RS-485 biasing can improve communications by eliminating indeterminate idle states. See the full *Mounting and Wiring Guide* for more details on RS485 biasing. Each RS485 port has two LEDs. See "[Status LEDs](#)," page 4.

Ethernet wiring

Two RJ-45 10/100/1000-Mbit Ethernet connectors are labeled PRI (LAN1) for *primary*, and SEC (LAN2) for secondary. Use a standard Ethernet patch cable to an Ethernet switch.

The factory-default IP address for PRI is 192.168.1.140. The default subnet mask is 255.255.255.0. By default, the SEC (LAN2) port is disabled.

Refer to the *JACE-8000 Niagara 4 Install and Startup Guide* for details on the software configuration of the Ethernet ports.

Power up and initial checkout

1. **Apply power.** To do this, do *one* of the following:
 - Insert the 2-position 24V power connector plug, or
 - Insert the barrel plug of the wall-mount AC adapter (WPM24-XXX).
2. **Check the STAT (Status) and BEAT (Heartbeat) LEDs.** When power is applied, the green “STAT” LED will light. This indicates the system is OK, with power applied. During bootup, the “BEAT” LED may blink at 1 Hz with a 90%/10% on/off duty cycle. When bootup completes, the platform daemon is started, and the normal 1 Hz flash at 50%/50% on/off duty cycle of the “BEAT” LED returns.

Status LEDs

The controller provides a number of status LEDs, with all but one visible with the front access door closed. See [Figure 6](#).

Figure 6 LEDs and brief descriptions.

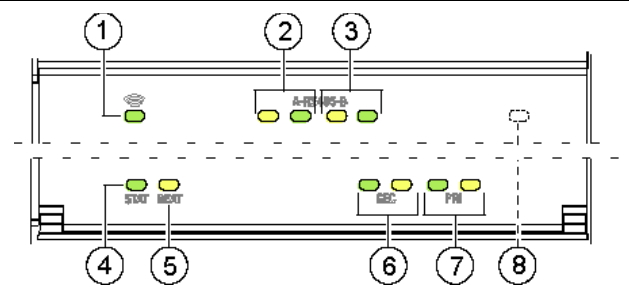

1	WiFi (Green) - Lit whenever WiFi config switch is not Off.
2	RS485 “A” (COM1): Transmit (TX) and Receive (RX).
3	RS485 “B” (COM2): Transmit (TX) and Receive (RX).
4	STAT (Green) - Remains lit while controller is powered.
5	BEAT (Yellow) - “Heartbeat”, normally 1Hz, 50% duty cycle.
6	Secondary Ethernet, SEC (LAN2) “Link” and “Activity”.
7	Primary Ethernet SEC (LAN1) “Link” and “Activity”.
8	(Behind Door) BACKUP - Green, typically Off.

If the “BEAT” LED stays on constantly, does not light, or blinks very fast, contact System Engineering for technical support.

Caution The 1Hz, 90%/10% on/off “BEAT” flash at bootup also occurs during other critical operations, such as a firmware upgrade to the controller and/or any attached modules. To be safe, do not remove power from the controller while its “BEAT” LED flashes with a 90%/10% on/off duty cycle. Wait for the normal (50%/50%) flash to return before removing power.

For details on the controller’s various LEDs and pushbutton switches, see the full *Mounting and Wiring Guide*.

Information and/or specifications published here are current as of the date of publication of this document. Tridium, Inc. reserves the right to change or modify specifications without prior notice. The latest product specifications can be found by contacting our corporate headquarters, Richmond, Virginia. Products or features contained herein are covered by one or more U.S. or foreign patents. This document may be copied by parties who are authorized to distribute Tridium products in connection with distribution of those products, subject to the contracts that authorize such distribution. It may not otherwise, in whole or in part, be copied, photocopied, reproduced, translated, or reduced to any electronic medium or machine-readable form without prior written consent from Tridium, Inc. Complete confidentiality, trademark, copyright and patent notifications can be found at: <http://www.tridium.com/galleries/SignUp/Confidentiality.pdf>. © 2015 Tridium, Inc.

USB ports and pushbutton switches

Behind the controller’s front access door are two USB ports, two pushbutton switches, and an associated LED.

Figure 7 USB ports and switches behind access door.

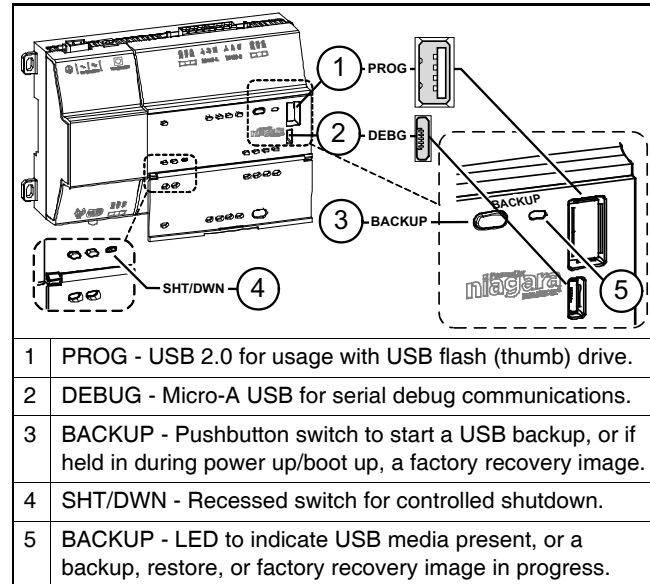

The DEBUG port is a standard Micro-A type USB port for serial debug communications to the controller. Use a serial terminal program (for example: PuTTY) to access the controller’s “system shell” menu. This provides access to a few basic platform settings.

Default DEBUG port settings are: 115200, 8, N, 1 (baud rate, data bits, parity, stop bits). For details on using a serial connection to the DEBUG port, see the *JACE Niagara 4 Install and Startup Guide*.

NOTE: Login requires admin-level platform credentials.

More information

Additional controller hardware details are in the full *Mounting and Wiring Guide*, including option module capacity considerations, RS485 biasing details, and status LED details.