

# UAC28-IP

User Manual

Hardware

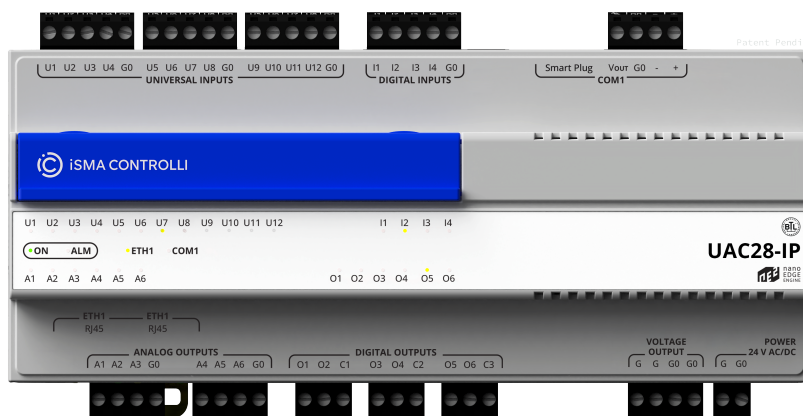

## Table of Contents

1	Introduction.....	4
1.1	Revision History.....	4
2	Safety Rules.....	5
3	Technical Specification.....	6
4	Hardware Specification.....	9
4.1	Dimensions [mm].....	9
4.2	Power Supply.....	9
4.3	Front View.....	10
4.4	Opening Top Panel.....	10
4.5	Ethernet Fail-safe Protected Ports.....	13
4.5.1	Address Pool Consistency.....	13
4.5.2	Ethernet Network Cable Length Requirements.....	14
4.6	SD card.....	16
4.7	RS485 Port.....	17
4.7.1	RJ45 Connector.....	17
4.7.2	RS485 Screw Connector.....	17
4.7.3	RS485 Pins.....	18
4.7.4	RS485 Grounding and Shielding.....	18
4.7.5	RS485 Network Termination.....	18
4.8	Front Panel.....	20
4.8.1	LED Indicators.....	20
4.8.2	DIP Switches.....	20
5	Default Communication Setting and Credentials.....	21
5.1	Default Communication Settings.....	21
5.1.1	Address Pool Consistency.....	21
5.1.2	DHCP.....	21
5.1.3	Changing Communication Settings.....	21
5.2	Default Credentials.....	22
5.3	Factory Default.....	22
5.3.1	Application Restore.....	23
6	Mounting and Installation.....	25
6.1	Mounting Orientation.....	25
6.1.1	Proper Placement.....	25
6.1.2	Improper Placement.....	26
6.2	Mounting Instructions.....	26
6.2.1	DIN Rail Mounting.....	26
6.2.2	Screw Mounting.....	27
7	Inputs and Outputs.....	29
7.1	Universal Inputs.....	29
7.1.1	Universal Input Voltage Connection.....	29
7.1.2	Universal Input Current Connection.....	29
7.1.3	Universal Input Resistance Connection.....	30

7.1.4	Universal Input Dry Contact Connection .....	31
7.2	Digital Inputs.....	31
7.2.1	Digital Input Counter.....	31
7.3	Analog Outputs.....	32
7.3.1	Analog Output Voltage Connection .....	32
7.3.2	Analog Output Relay Connection .....	32
7.3.3	Analog Output Actuator Connection.....	33
7.4	Digital Outputs.....	33
7.4.1	Digital Output Electrovalve Connection.....	33
7.4.2	Digital Output Resistive Load Connection .....	34
7.4.3	Digital Output Inductive Load Connection.....	34
8	List of Supported Temperature Sensors .....	35

## 1 Introduction

UAC28-IP is a freely programmable controller with the nano EDGE ENGINE embedded. It is Niagara-enabled and IP-based controller with built-in 28 I/Os, fail-safe Ethernet switch, and RS485 port with screw terminal and the Smart Plug™ for easy connection of iC wall panels for occupancy, fan, comfort, light and blinds control.

Ideal solution for HVAC and lighting control in two different zones, with a native support for IP communication with BACnet and Modbus protocols.

### 1.1 Revision History

Date	Manual rev.	Description
21 Apr 2026	1.0.0-beta	Beta edition

## 2 Safety Rules

- Improper wiring of the product can damage it and lead to other hazards. Make sure that the product has been correctly wired before turning the power on.
- Before wiring or removing/mounting the product, make sure to turn the power off. Failure to do so might cause an electric shock.
- Do not touch electrically charged parts such as power terminals. Doing so might cause an electric shock.
- Do not disassemble the product. Doing so might cause an electric shock or faulty operation.
- Use the product only within the operating ranges recommended in the specification (temperature, humidity, voltage, shock, mounting direction, atmosphere, etc.). Failure to do so might cause a fire or faulty operation.
- Firmly tighten the wires to the terminal. Failure to do so might cause a fire.
- Avoid installing the product in close proximity to high-power electrical devices and cables, inductive loads, and switching devices. Proximity of such objects may cause an uncontrolled interference, resulting in an instable operation of the product.
- Proper arrangement of the power and signal cabling affects the operation of the entire control system. Avoid laying the power and signal wiring in parallel cable trays. It can cause interferences in monitored and control signals.
- It is recommended to power controllers/modules with AC/DC power suppliers. They provide better and more stable insulation for devices compared to AC/AC transformer systems, which transmit disturbances and transient phenomena like surges and bursts to devices. They also isolate products from inductive phenomena from other transformers and loads.
- Power supply systems for the product should be protected by external devices limiting overvoltage and effects of lightning discharges.
- Avoid powering the product and its controlled/monitored devices, especially high power and inductive loads, from a single power source. Powering devices from a single power source causes a risk of introducing disturbances from the loads to the control devices.
- If an AC/AC transformer is used to supply control devices, it is strongly recommended to use a maximum 100 VA Class 2 transformer to avoid unwanted inductive effects, which are dangerous for devices.
- Long monitoring and control lines may cause loops in connection with the shared power supply, causing disturbances in the operation of devices, including external communication. It is recommended to use galvanic separators.
- To protect signal and communication lines against external electromagnetic interferences, use properly grounded shielded cables and ferrite beads.
- Switching the digital output relays of large (exceeding specification) inductive loads can cause interference pulses to the electronics installed inside the product. Therefore, it is recommended to use external relays/contactors, etc. to switch such loads. The use of controllers with triac outputs also limits similar overvoltage phenomena.
- Many cases of disturbances and overvoltage in control systems are generated by switched, inductive loads supplied by alternating mains voltage (AC 120/230 V). If they do not have appropriate built-in noise reduction circuits, it is recommended to use external circuits such as snubbers, varistors, or protection diodes to limit these effects.

### 3 Technical Specification

Power supply	DC	24 VDC $\pm$ 20%, 12.3 W
	AC	24 V AC $\pm$ 20%, 30 VA
Vout (COM1)	Max. load	Max. 5 W, max. 40 VDC - depending on the input supply voltage 23 VDC for 24 VDC input supply voltage 33 VDC for 24 V AC input supply voltage
Voltage output	Max. load	Max. total load on Vout (COM1) and voltage output: 12 W
Universal inputs	Number of inputs	12
	Voltage input	Voltage measurement: 0-10 VDC Input impedance: 100 k $\Omega$ Measurement accuracy: $\pm$ 0.1% Measurement resolution: 3 mV at 12-bit and 1 mV at 16-bit
	Current input	Current measurement: 0-20 mA Required external resistor: 200 $\Omega$ Measurement accuracy: $\pm$ 1.1% Measurement resolution: 15 $\mu$ A at 12-bit and 5 $\mu$ A at 16-bit
	Digital input	Output current $\sim$ 1 mA
	Resistance input	Measurement of resistance: 0-1000 k $\Omega$ Measurement resolution for 20 k $\Omega$ load: 20 $\Omega$ at 12-bit and 1 $\Omega$ at 16-bit Measurement resolution for PT1000 and NI1000: 0.1 $\Omega$ at 16-bit Resistance measurement method: voltage divider
	Temperature input	Measurement with attached RTDs (resistance temperature detectors) Accuracy: $\pm$ 0.1C The PT1000 and NI1000 sensors use 16-bit resolution
	Measurement resolution	12-bit (default), 16-bit
	Processing time	10 ms/channel at 12-bit 140 ms/channel at 16-bit
Digital inputs	Number of inputs	4
	Type	Dry contact or fast pulse counter (saved on SD card)
	Max. input frequency	100 Hz

Analog outputs	Number of outputs	6
	Voltage range	0-10 VDC
	Max. load current	20 mA
	Resolution	12-bit
	Accuracy	±0.5%
	PWM	0.01 Hz, 0.1 Hz, 1 Hz, 10 Hz, 100 Hz
Digital Outputs	Number of outputs	6
	Resistive load (AC1)	3 A at 230 V AC, 3 A at 30 VDC
	Inductive load (AC3)	75 VA at 230 V AC or 30 W at 30 VDC
COM1	RS485 communication	Up to 128 devices
	Communication protocol	BACnet MS/TP, Modbus RTU
	Connectors	Smart Plug (RJ45), screw connector
	Baud rate	2400-115200
ETH1	Switches	2 ports, fail-safe protected
	Communication protocol	BACnet IP, Modbus TCP/IP
	Baud rate	10/100 Mb/s
USB1	Type	USB-C
	Power supply	5 V
Ingress protection	IP rating	IP 20 for indoor installation
Temperature	Storage	-40°C to +85°C (-40°F to +185°F)
	Operating	0°C to +50°C (32°F to 122°F)
Humidity	Relative	5 to 95% RH (without condensation)
Connector cables	RS485 and IOs	Separable max. 2.5 mm <sup>2</sup> (18 – 12 AWG)
	RS485	RJ45
	Ethernet	RJ45

	Min. cable category	UTP 5E
<b>Housing</b>	Material	Plastic, self-extinguishing PC/ABS
<b>Mounting</b>	DIN rail mounting	DIN EN 50022
<b>Dimensions (12M)</b>	Width	215.50 mm/8.48 in
	Length	109.40 mm/4.31 in
	Height	61.70 mm/2.43 in

## 4 Hardware Specification

### 4.1 Dimensions [mm]

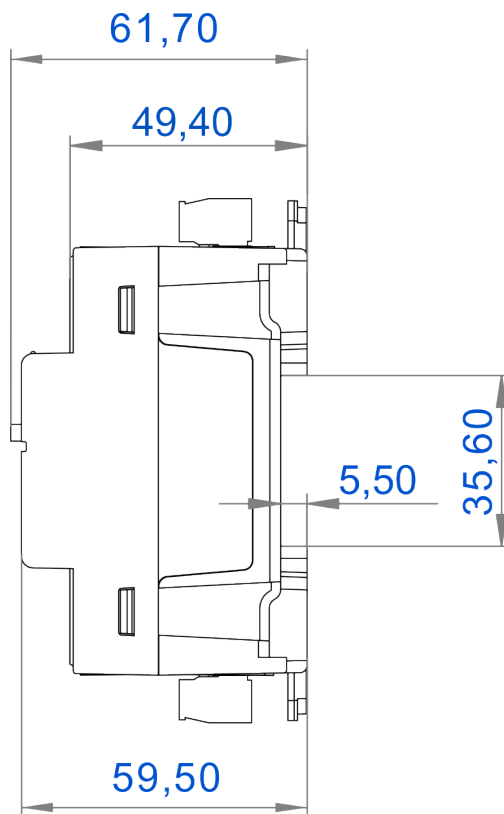
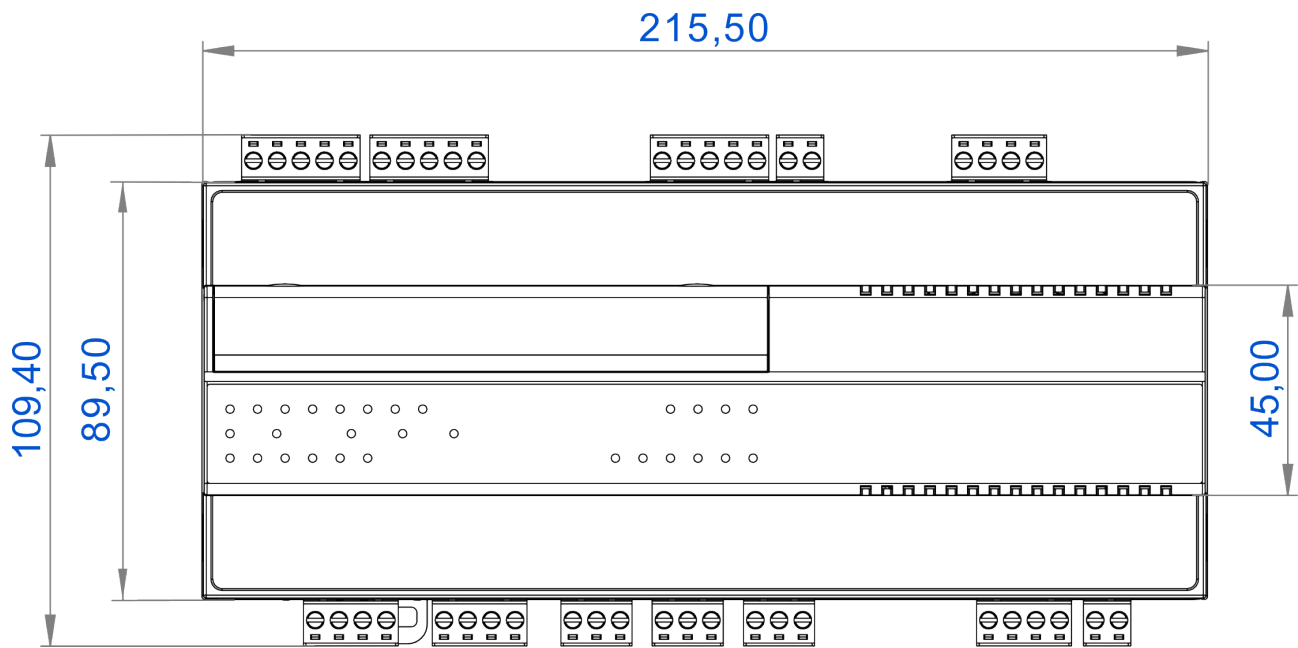

### 4.2 Power Supply

The UAC28-IP controller requires 24 V AC/DC power supply.

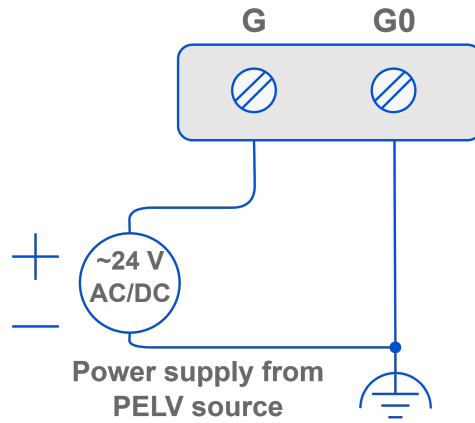

Figure 3. Power supply connection

It is also possible to power the controller using a USB cable (5 V power supply).

**Warning!**  
5 V USB power supply does not support AO/DO/Vout/Voltage outputs in the controller.

### 4.3 Front View

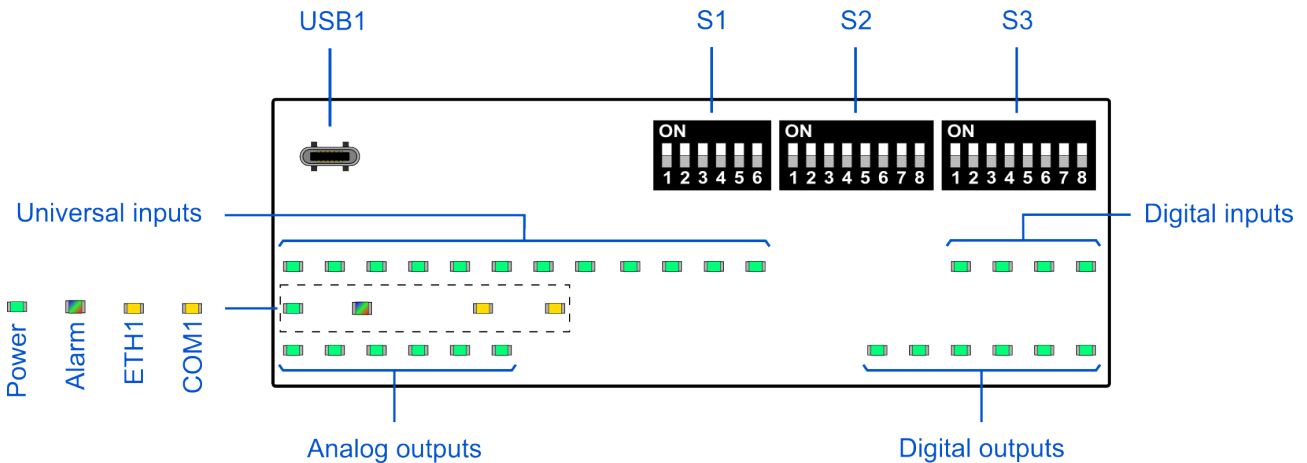
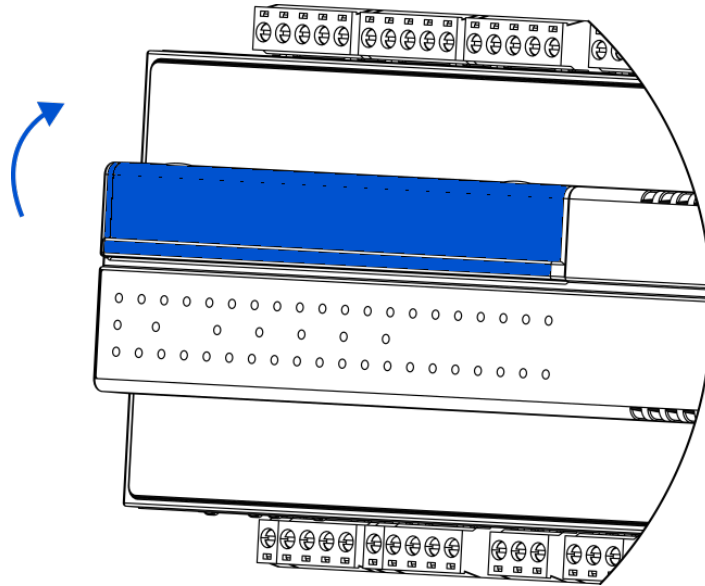

Figure 4. UAC28-IP top panel

### 4.4 Opening Top Panel

1. Lift the blue cover up.



2. After a click, the cover is semi-opened and upheld in this position.

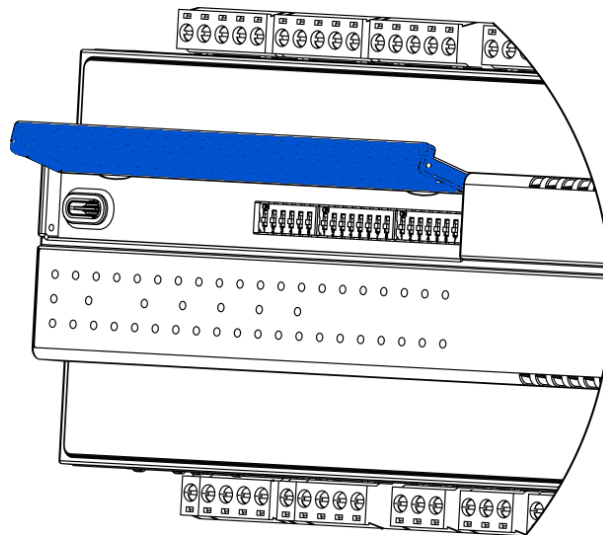

3. It is possible to lift the cover to a fully open position.

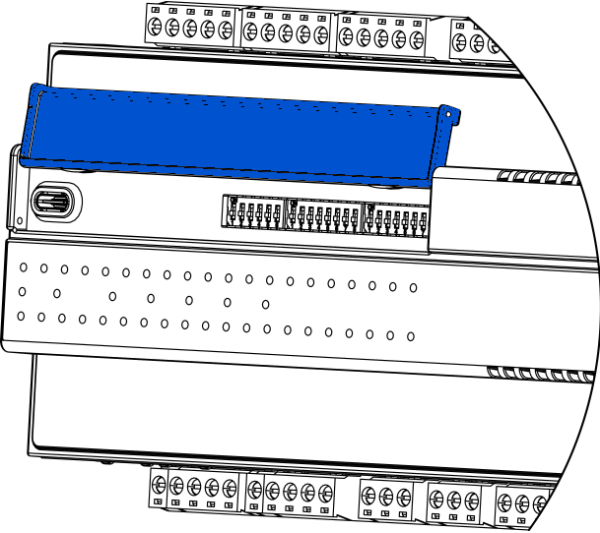

4. To close the cover, pull it down.

## 4.5 Ethernet Fail-safe Protected Ports

The UAC28-IP controller is equipped with two Ethernet ports operating in a switch mode, designed to connect controllers in a daisy chain mode without the need for additional hardware switches.

Due to the specifics of the Ethernet network daisy chain topology, the Ethernet port of the controller is fail-safe protected, ensuring the communication continuity in such network topology. The transmission is maintained even if one of the controllers on the network is not being powered.

The fail-safe functionality allows the continuity of data transmission through the device, despite of possible power supply breaks. In normal conditions, the data packets coming in are sent through the switch, which ensures communication with further connected devices. However, if the controller runs into power failure, thanks to the fail-safe mechanism, the communication between connected devices is maintained, and the data packets are still transmitted to the devices further in the network, ensuring the communication continuity. Devices that are not equipped with the fail-safe protection break the communication continuity in case of the power supply failure, despite of having a built-in switch. The mechanism ensures the Ethernet communication is not broken in any conditions.

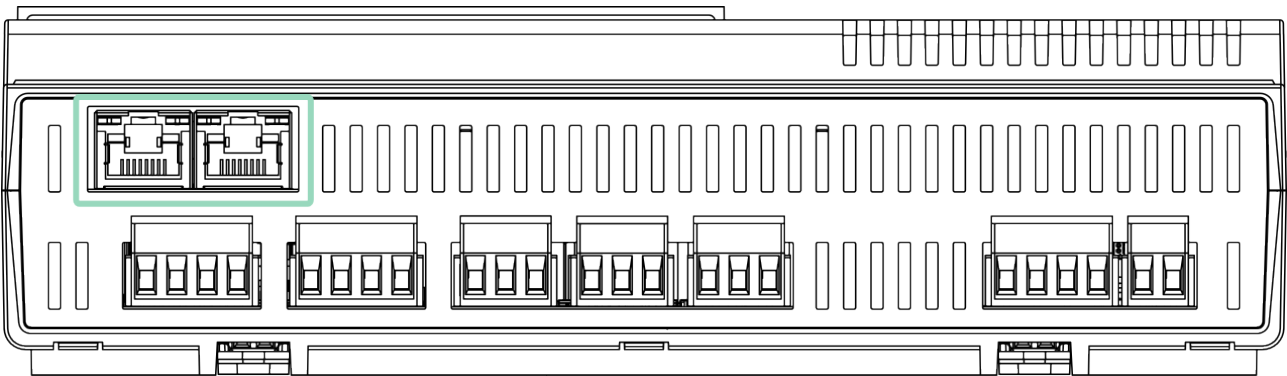

Figure 5. Ethernet port

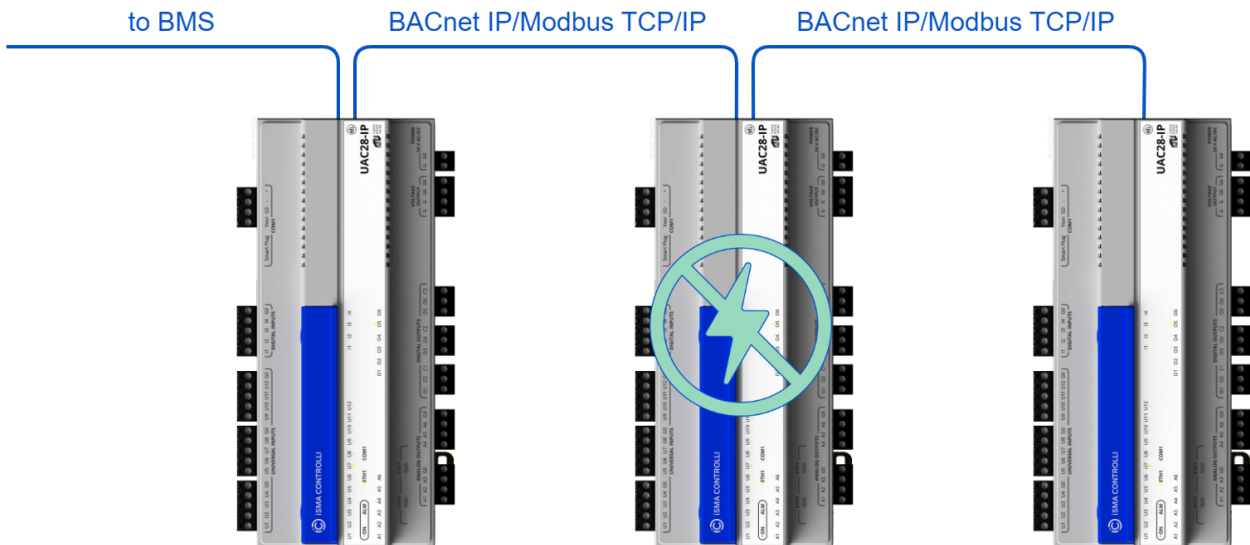

Figure 6. Network communication maintained with one device not powered up

### 4.5.1 Address Pool Consistency

The Ethernet IP interface can be used to connect the device to the computer network, which it will work in, or to the computer itself. If the device is connected to the computer network, make sure that the IP address of the device is in line with the address range of the computer network. In case it differs, the device first needs to be connected directly to the computer and have its IP address changed manually. In

such case, the Ethernet TCP/IPv4 connection needs to be fixed manually, making sure that the device's network parameters (IP address, mask, and default gateway's) are consistent with the Ethernet connection's address pool.

## 4.5.2 Ethernet Network Cable Length Requirements

According to the Ethernet Cat5 cabling standard, the maximum distance between 2 Ethernet devices cannot exceed 100 m/328.08 ft. A total cable length between 2 communicating devices on the network cannot exceed 100 m/328.08 ft. If there are devices on the network, which have lost communication, the maximum cable length between next two working controllers still cannot exceed 100 m/328.08 ft. The below diagrams depict possible scenarios for correct connections and scenarios, where the cabling length exceeds the allowed limits.

Minimum cable category: UTP 5E.

### Examples of a proper fail-safe protection in daisy chain connections

For daisy chain connections, the maximum length between 2 working controllers must not exceed 100 m/328.08 ft. In the diagram below, green icons represent working controllers on the network, and red icons represent controllers, which are not communicating:

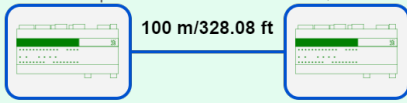

Maximum length of 100 m/328.08 ft between 2 working controllers

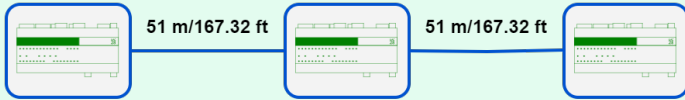

Maximum length of 51 m/167.32 ft between 2 working controllers



Total length of 98 m/321.52 ft between 2 working controllers

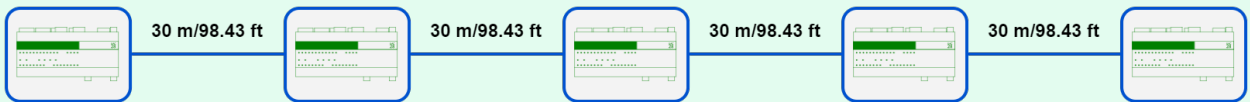

Total length of 30 m/98.43 ft between 2 working controllers



Total length of 90 m/295.28 ft between 2 working controllers and 30 m/98.43 ft to the next working controller - at no point does the distance between 2 working controllers exceed 100 m/328.08 ft

### Examples of an inadequate fail-safe protection in daisy chain connections

For daisy chain connections, the maximum length between 2 working controllers must not exceed 100 m/328.08 ft. In the diagram below, green icons represent working controllers on the network, and red icons represent controllers, which are not communicating:

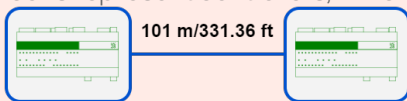

Total length of 101 m/331.36 between 2 working controllers exceeds the maximum range of 100 m/328.08 ft



Total length of 102 m/334.65 ft between 2 working controllers exceeds the maximum range of 100 m/328.08 ft



Total length of 120 m/393.7 ft between 2 working controllers exceeds the maximum range of 100 m/328.08 ft

## 4.6 SD card

The SD card is a core of the UAC28-IP device. The SD card contains all software elements that guarantee a proper device functioning: real-time operating system and libraries.

The SD card is originally located inside the device. The card socket is placed on the side:

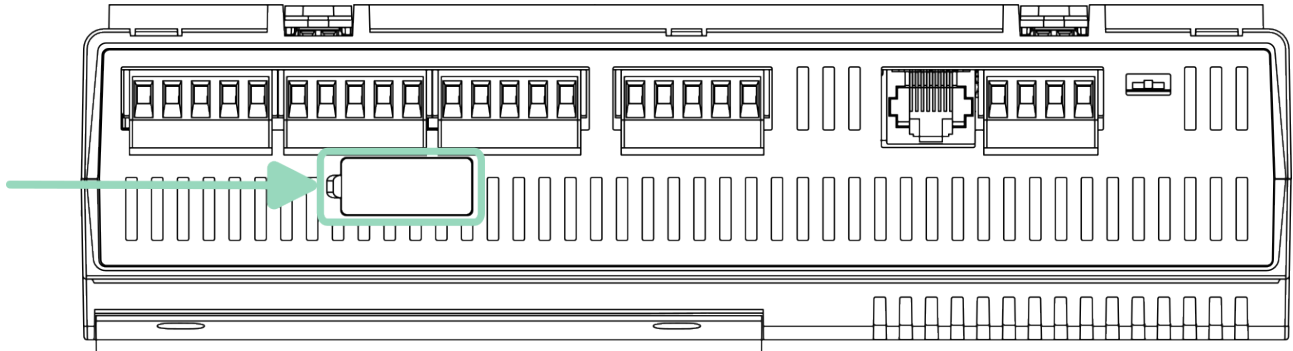

Figure 7. Location of the SD card socket

In case the device has suffered a hardware failure, it is possible to take the SD card out of the broken device and insert it into a replacement unit.

In order to access the SD card in the device:

- Turn the power supply off.
- Discharge any static electricity by touching a known, securely grounded object.
- The SD card socket is located on the side of the device (as per the above figure). The socket is covered with a protective sticker. Use a thin object to lift the edge of the sticker to uncover the socket.
- Remove the SD card by pushing the card in, until the spring release pushes the card partially out of the card socket. Grasp the card, and pull it completely out of the unit.

### Warning

It is strongly not recommended to take out the SD card in any other situation other than a permanent hardware failure. Repeated lifting of the protective sticker may compromise its preventive features and reduce its durability.

## 4.7 RS485 Port

The UAC28-IP device is equipped with an RS485 port with two connectors: RJ45 and screw connector, which translates to the universal functionality of the RS485 port.

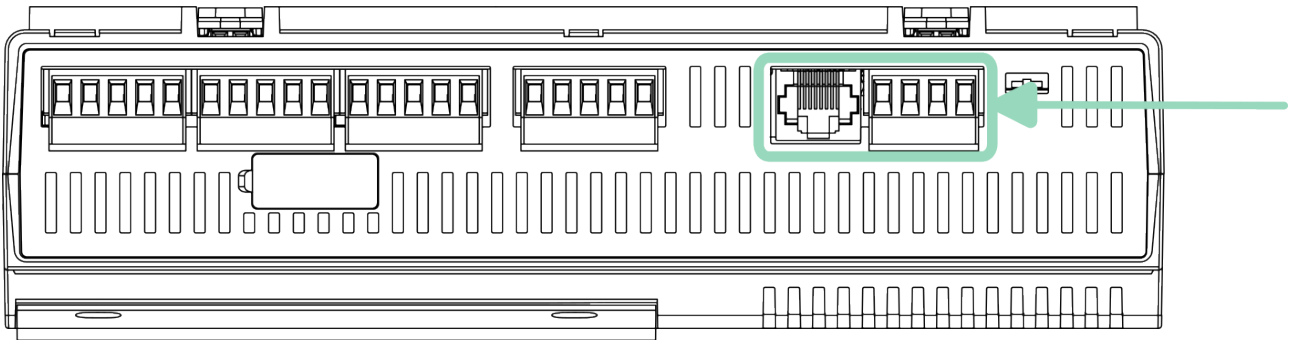

Figure 8. COM1 RS485 port

### 4.7.1 RJ45 Connector

The RJ45 connector allows to connect a dedicated room panel.

The RJ45 socket also provides power supply dedicated for external room panel.

### 4.7.2 RS485 Screw Connector

The RS485 port is also equipped with a screw connector, which allows connecting with other devices in the network.

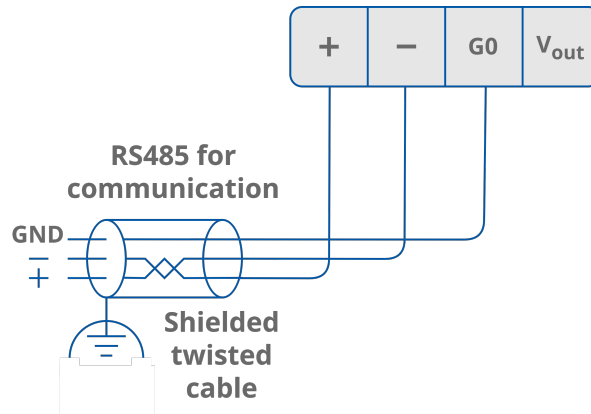

Figure 9. RS485 connection

The screw connector allows to connect separable cables of diameter as thin as 2.5 mm<sup>2</sup> (18 – 12 AWG).

### 4.7.3 RS485 Pins

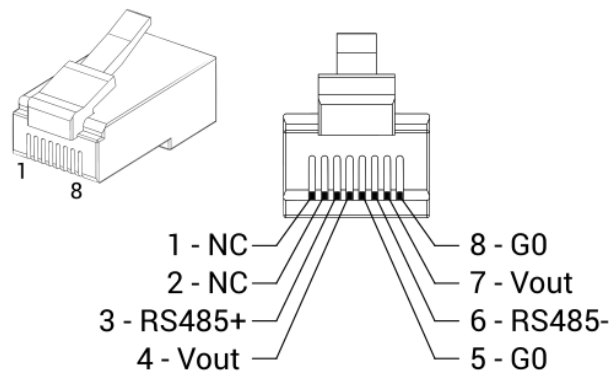

Figure 10. RS485 pins

### 4.7.4 RS485 Grounding and Shielding

In most cases controllers are installed in enclosures along with other devices, which generate electromagnetic radiation (for example, relays, contactors, transformers, motor invertors, etc.). Such electromagnetic radiation can induce electrical noise into both power and signal lines, as well as direct radiation into the controller, causing negative effects on the system. For this reason, an appropriate grounding, shielding, and other protective steps should be taken at the installation stage to prevent negative electromagnetic radiation effects, for example:

- control cabinet grounding;
- cable shield grounding;
- using protective elements for electromagnetic switching devices;
- proper wiring;
- consideration of cable types and their cross sections;
- and other.

### 4.7.5 RS485 Network Termination

Transmission line effects often present problems for data communication networks. These problems include reflections and signal attenuation.

To eliminate the presence of reflections of signal from the end of the cable, the cable must be terminated at both ends with a resistor across the line adequate to its characteristic impedance. Both ends must be terminated since the propagation is bidirectional. In case of an RS485 twisted pair cable this termination is typically 120  $\Omega$ .

In the UAC28-IP there is a built-in, 3-position switch on the right side of the device, which is dedicated to connecting termination resistor and/or biasing resistors.

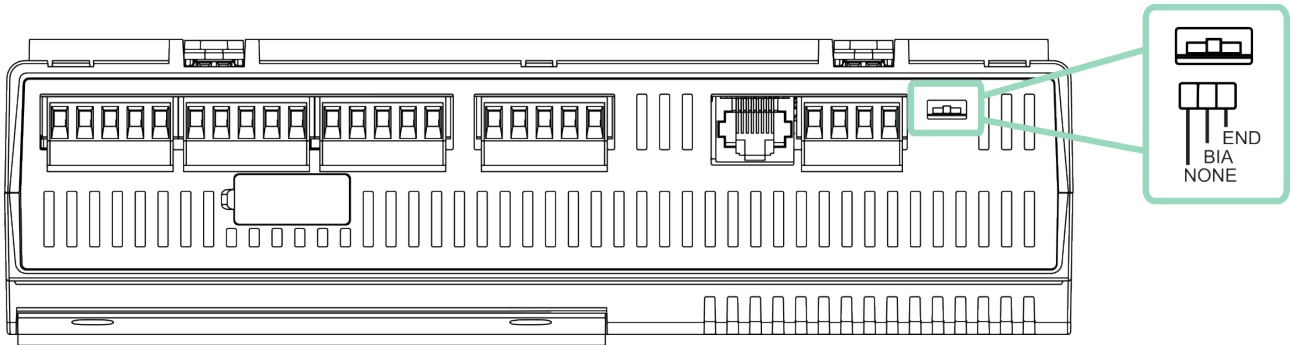

Figure 11. RS485 network termination

Switch Position	Biasing	Termination 120 Ω
NONE (default)	Off	Off
BIA	On	Off
END	On	On

Instead of using additional resistors, the termination and biasing can easily be done by a simple switch activation.

If the switch is in the END position, it connects the termination resistor 120 Ω and biasing resistors 680 Ω (pull-down to ground G0 and pull-up to +5 V DC) to the RS485 bus.

If the switch is in the BIA position, it connects the biasing resistors 680 Ω (pull-down to ground G0 and pull-up to +5 V DC) to the RS485 bus. The biasing is added to the RS485 bus in order to reduce communication failures.

By default, the switch is set to the NONE position, both biasing and termination are off.

**Warning**

Only one single device on the network can have biasing resistors connected. Connecting biasing resistors on two or more devices on a single RS485 bus will take the opposite effect—increase the number of communication problems.

## 4.8 Front Panel

The UAC28-IP controller has a front panel equipped with LED status diodes and three configuration DIP switches.

### 4.8.1 LED Indicators

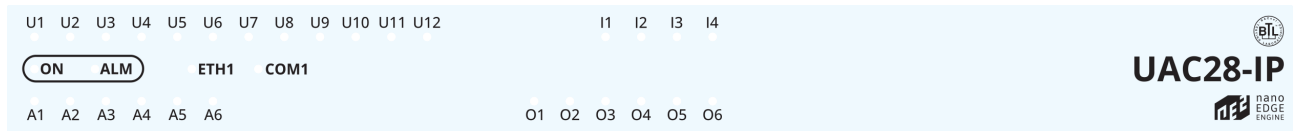

Figure 12. UAC28-IP LED panel

- The ON LED (power) is on (green) when the controller is running properly. The ON LED blinks with 5 Hz frequency when the device is starting and during SD card diagnostics.

**Note:** If the frequent blinking continues for over 10-15 seconds, it means the SD card is being recovered as a result of the diagnostics process. Each time the device is started, it runs a diagnostic process, which checks if the SD card is available and the device is fully operable. If the diagnostics process does not return any necessary fixes, the blinking ceases after a few seconds.

- The ALM LED (red) lights up if the device is in the emergency mode.
- The ETH1 LED lights up (orange) after sending each data packet when connected to the programming tool. As long as the controller receives/sends packets, the LED blinks continuously.
- The COM1 LED lights up for RS485 communication.
- U1-U12 LEDs light up when resistance connected to the input is less than 5 kΩ (dry contact input is active).

**Note:** U1-U12 LED also lights up when voltage connected to the input has a very low potential.

- I1-I4 LEDs light up when the connected contact is closed.
- A1-A6 LEDs light up when the output's voltage or PWM factor is different from 0, or the Out slot of the AnalogOutput component is true (when in digital mode).
- O1-O6 LEDs light up when the Out slot of the DigitalOutput component is true.

### 4.8.2 DIP Switches

The UAC28-IP device is equipped with three DIP switches, two 8-position ones (S2, S3) and a 6-position (S1). DIP switches can be freely used in client's application. Each of 6/8 switches has true or false state; they are dedicated for setting configuration in the user's application.

**Note:** The 6<sup>th</sup> switch on the S1 DIP switch is to [restore factory default settings](#) in the device.

To access DIP switches, lift the blue cover.

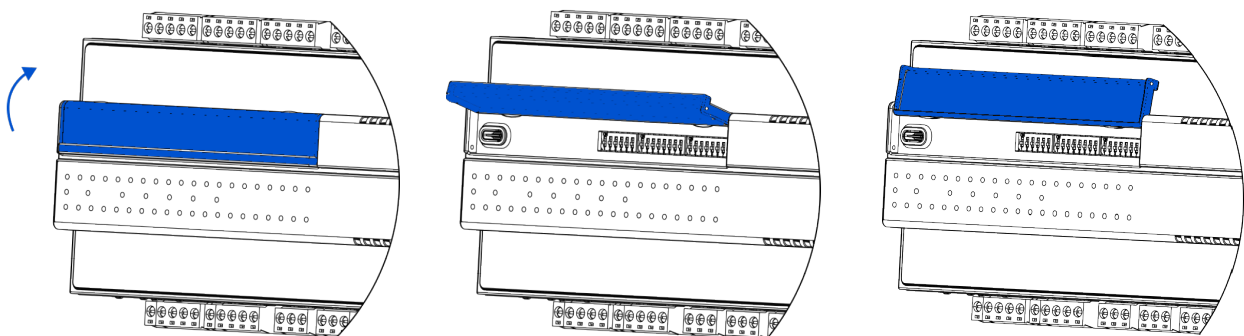

Figure 13. Accessing DIP switches

## 5 Default Communication Setting and Credentials

### 5.1 Default Communication Settings

The UAC28-IP default network communication settings are:

- IP address: 192.168.1.123;
- mask: 255.255.255.0;
- default gateway: 192.168.1.1.

#### 5.1.1 Address Pool Consistency

The Ethernet IP interface can be used to connect the device to the computer network, which it will work in, or to the computer itself. If the device is connected to the computer network, make sure that the IP address of the device is in line with the address range of the computer network. In case it differs, the device first needs to be connected directly to the computer and have its IP address changed manually. In such case, the Ethernet TCP/IPv4 connection needs to be fixed manually, making sure that the device's network parameters (IP address, mask, and default gateway's) are consistent with the Ethernet connection's address pool.

#### 5.1.2 DHCP

Apart from setting the device's IP address manually, in the UAC28-IP, it is possible to use the DHCP protocol, which automatically attributes an IP address to the device from the DHCP server.

To enable the DHCP protocol, go to the [Ethernet1](#) component in the System container, and set the DHCP Enabled slot to true.

##### Warning!

The DHCP server will automatically assign a new IP address after restarting the device. Communication using the existing IP address will no longer be possible.

#### AutoIP Mechanism

In case the DHCP is enabled and the DHCP server is unavailable, the AutoIP mechanism is launched to provide the IP address.

The AutoIP mechanism assigns the device the IP address from range of 169.254.0.(0-16), which are reserved for a private use. The mechanism provides the IP address and mask, but not the gateway and DNS.

#### 5.1.3 Changing Communication Settings

The default communication settings can be changed in the [Ethernet1](#) component, which is located in the Platform component in the System container.

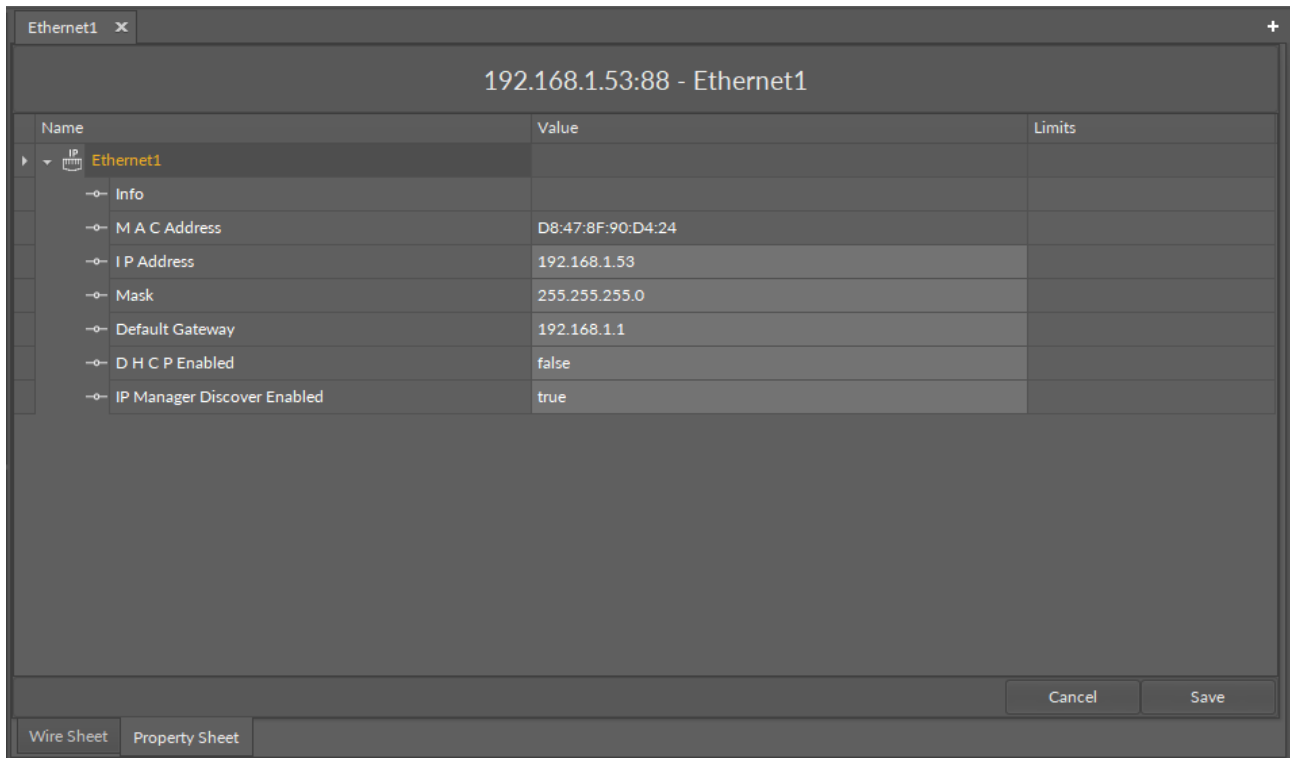

Figure 14. Ethernet1 component

## 5.2 Default Credentials

With the example application on the controller, the UAC28-IP default credentials are:

- Username: admin
- Password: Admin123!

Without the example application on the controller, the UAC28-IP default credentials are:

- Username: admin
- Password: admin

## 5.3 Factory Default

Restoring factory default settings erases all user configuration from the device:

- it restores the default IP address;
- it clears the user application;
- it clears all other user configuration.

In order to restore the device to its default settings, use the 6<sup>th</sup> switch on the 6-position DIP switch installed in the front panel. The process of restoring default settings of the controller includes the following steps:

**Step 1:** Disconnect the device in the iC Tool.

**Step 2:** Switch the 6<sup>th</sup> switch on the 6-position DIP switch to the on position.

**Step 3:** Turn the power supply off, and wait until the power LED switches off.

**Step 4:** Turn the power supply on, and wait until the power LED starts blinking.

**Step 5:** Switch the 6<sup>th</sup> switch to off position, and wait until only the power LED lights constantly.

**Step 6:** The device is restored to factory settings and ready to use.

**Cancelling the Restore to Factory Settings Procedure:**

The process of restoring factory settings can be reversed until **Step 4**. In order to cancel the procedure, follow the alternative steps:

Step 5: Turn the power supply off.

Step 6: Switch the 6<sup>th</sup> switch to the off position.

Step 7: Turn the power supply back on. The device is not restored, all configuration remains intact.

**Warning - Factory Default Deletes Application**

The process of bringing back factory default settings **erases the application from the controller**. In such a case, it is required to restore the application from the available backup.

### 5.3.1 Application Restore

To restore the application, which has been deleted in the process of bringing back the factory default settings, follow the below steps:

**Step 1:** Log in to the controller using default credentials:

- username: admin
- password: admin
- IP address: 192.168.1.123
- mask: 255.255.255.0
- default gateway: 192.168.1.1

**Step 2:** Go to the Backup Manager (depending on the used tool: [iC Tool](#) or [nE2 Link](#) Niagara module).

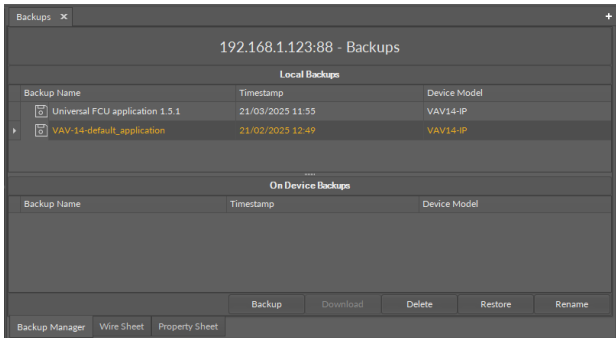

Figure 15. Application backup in the iC Tool

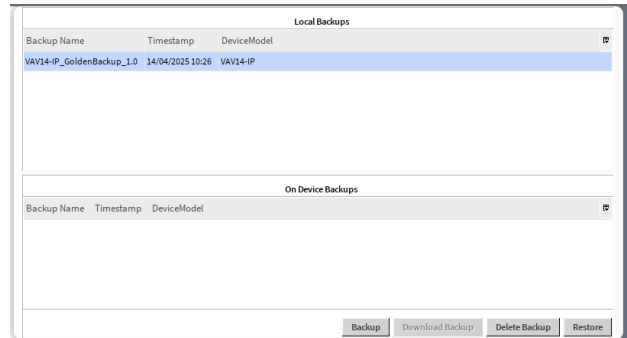

Figure 16. Application backup in the nE2 Link module

**Step 3:** Select the backup to restore.

**Step 4:** Click the Restore button. A pop-up window will appear to confirm restoring of the backup. Click Yes to start the restoring process.

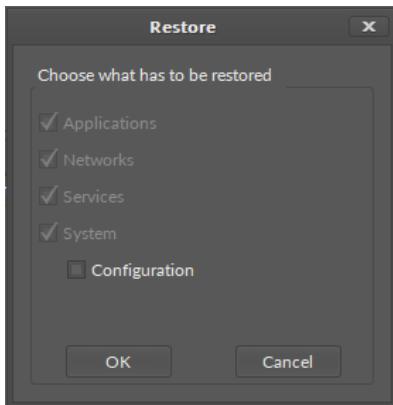

Figure 17. Restore pop-up in iC Tool

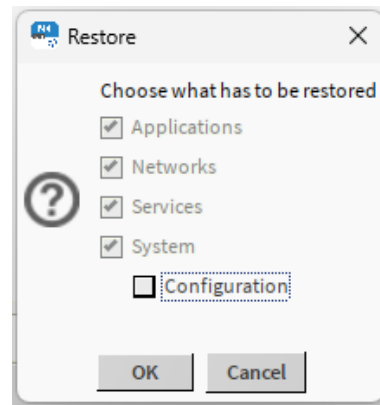

Figure 18. Restore pop-up in iC Workbench

While restoring a backup, it is possible to decide whether the configuration settings are restored from the backup too, or left as set on the device. By default, the option to restore configuration settings from a backup is unchecked.

The configuration settings include:

- iFnet port,
- IP address,
- mask,
- default gateway,
- DHCP enabled,
- device name,
- DNS1,
- DNS2,
- BACnet LocalDevice ID.

## 6 Mounting and Installation

### 6.1 Mounting Orientation

#### 6.1.1 Proper Placement

The controller is properly placed when:

- the space between the controller and the wiring ducts is at least 40 mm / 1.5 in,
- the controller is placed top side up (the blue panel is located over the LEDs panel).

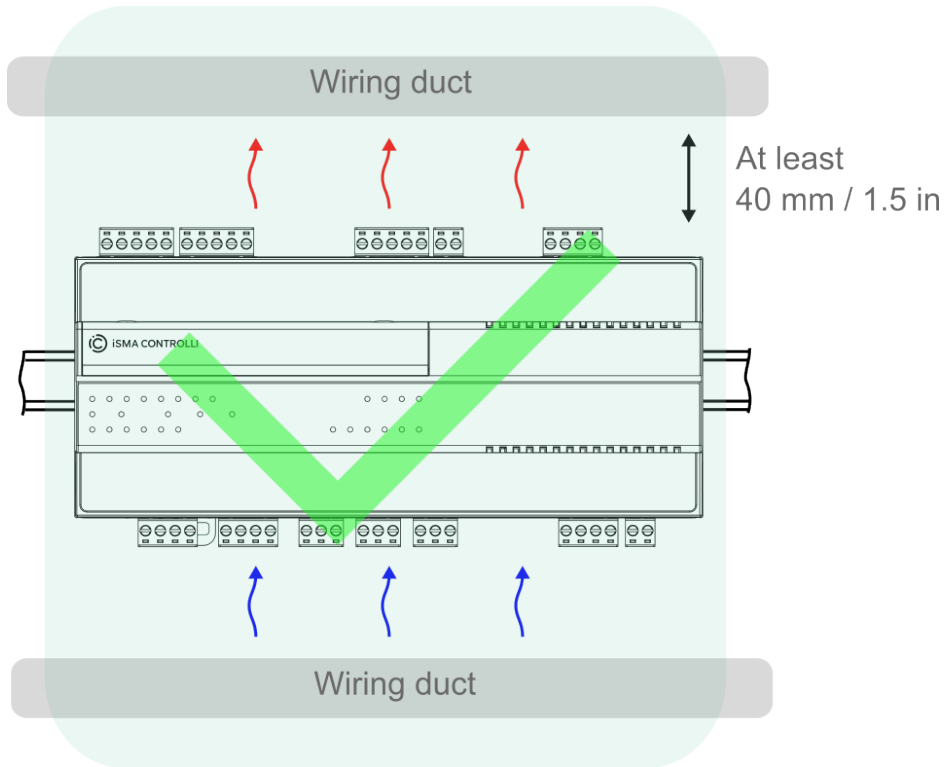

Figure 19. Proper installation of the controller

## 6.1.2 Improper Placement

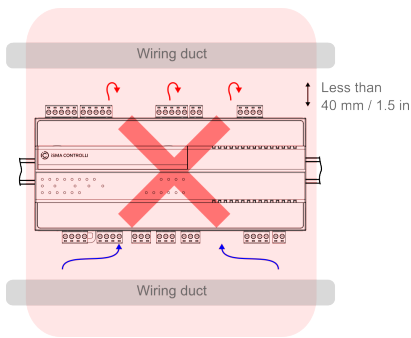

Figure 20. Improper placement: not enough space between the controller and wiring duct

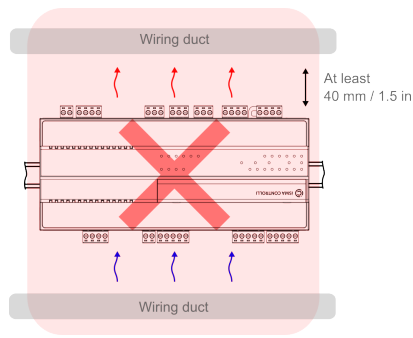

Figure 21. Improper placement: enough space between the controller and wiring duct but the controller is placed upside down

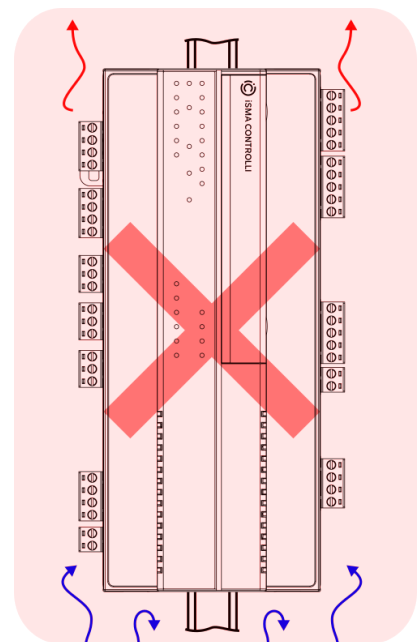
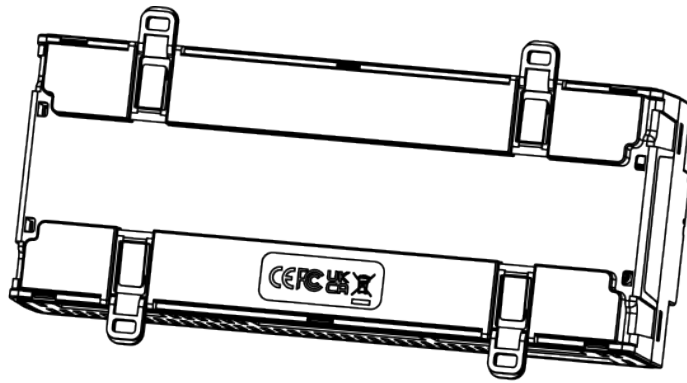

Figure 22. Improper placement: the controller is placed short side up

## 6.2 Mounting Instructions

### 6.2.1 DIN Rail Mounting

1. Make sure the hooks are in open position, tip of the hooks do not stick out into rail cavity in enclosure.



Open

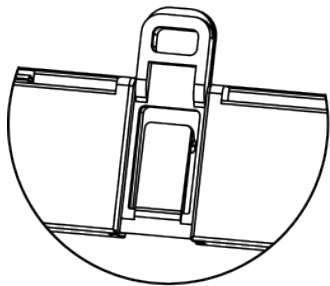

Close

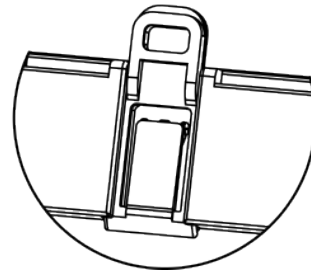

2. Place the controller on the DIN rail and close the hooks.

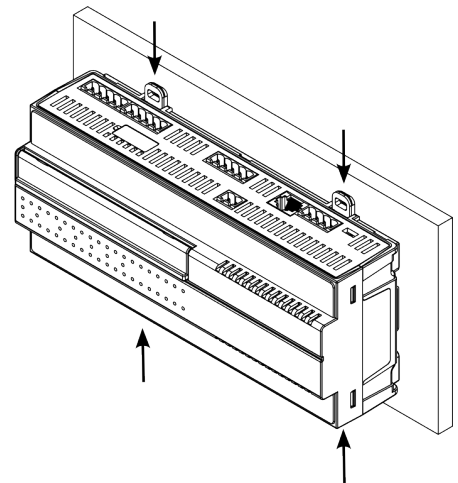
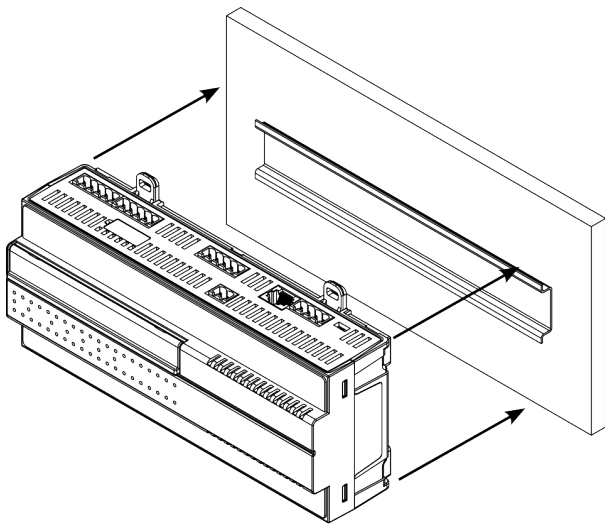

## 6.2.2 Screw Mounting

1. Set hooks into open position and put device next to the wall, use openings in hooks for marking pilot holes position.

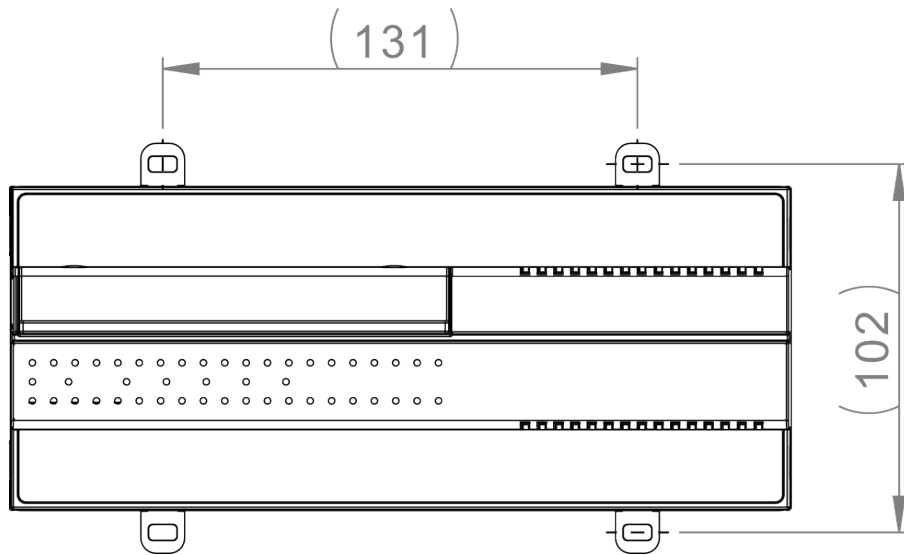

2. Screw the controller to the wall, using screws of max. diameter of 4.2 mm.

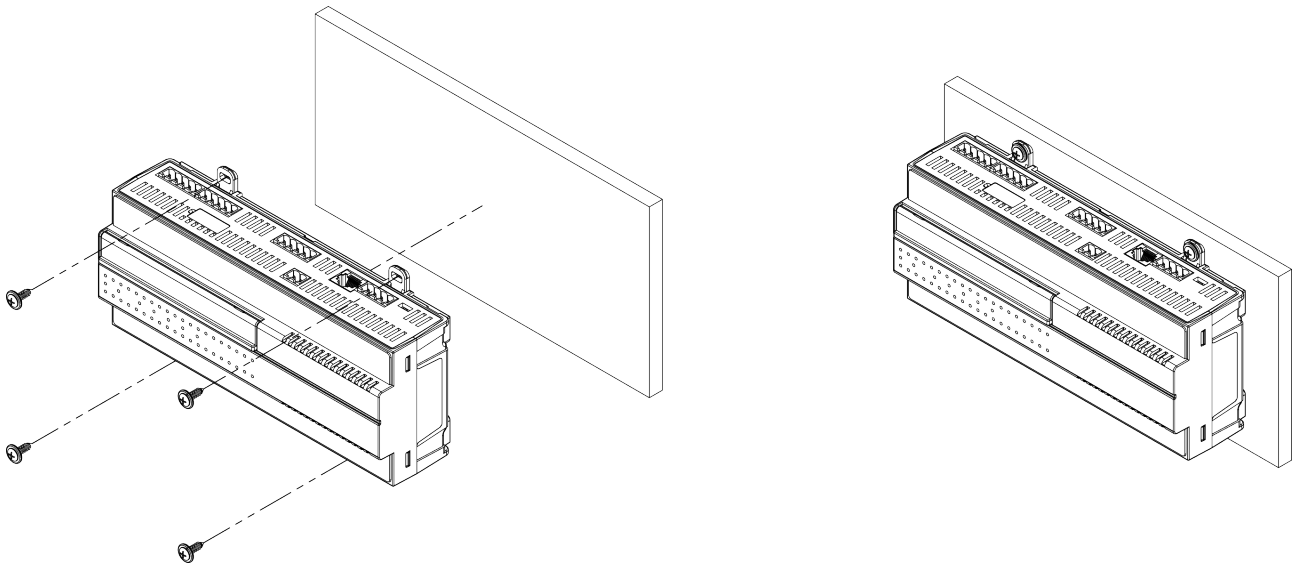

## 7 Inputs and Outputs

The UAC28-IP is equipped with 28 inputs and outputs:

- 12 universal inputs,
- 4 digital inputs,
- 6 analog outputs,
- 6 digital outputs.

### 7.1 Universal Inputs

The UAC28-IP device is equipped with 12 universal inputs.

Universal inputs support four types of input signals:

- voltage (0-10 V DC, input impedance 100 k $\Omega$ );
- current (0-20 mA);
- resistance and temperature measurement (10k thermistor, a full list of supported temperature sensors is available here: [List of Supported Temperature Sensors](#));
- dry contact (output current 1 mA).

#### 7.1.1 Universal Input Voltage Connection

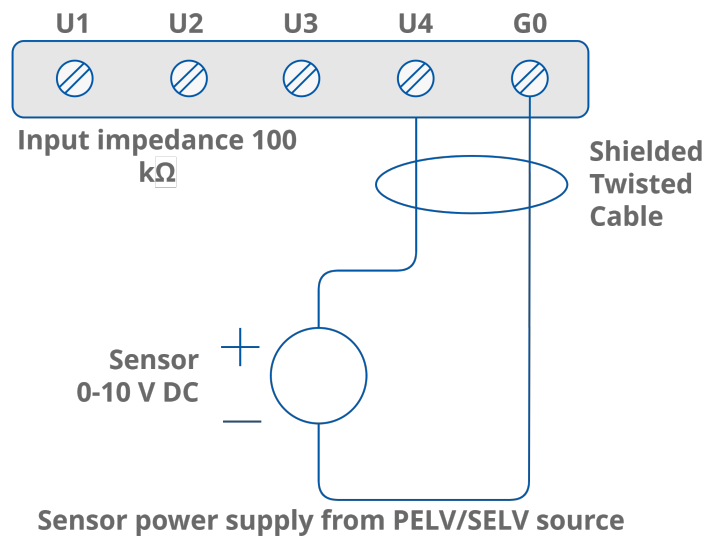

Figure 23. Universal input voltage connection

#### 7.1.2 Universal Input Current Connection

Current measurement is realized by voltage measurement and 200  $\Omega$  resistance. According to Ohm's law, the current is directly proportional to the voltage, and the resistance is the constant of proportionality. ( $I = U / R$ ). According to the Ohm's law equation, for 20 mA current with 200  $\Omega$  resistance the output voltage is 4 V. It means that the 4 V voltage measured on the universal input corresponds to 20 mA current. The result is expressed in millivolts.

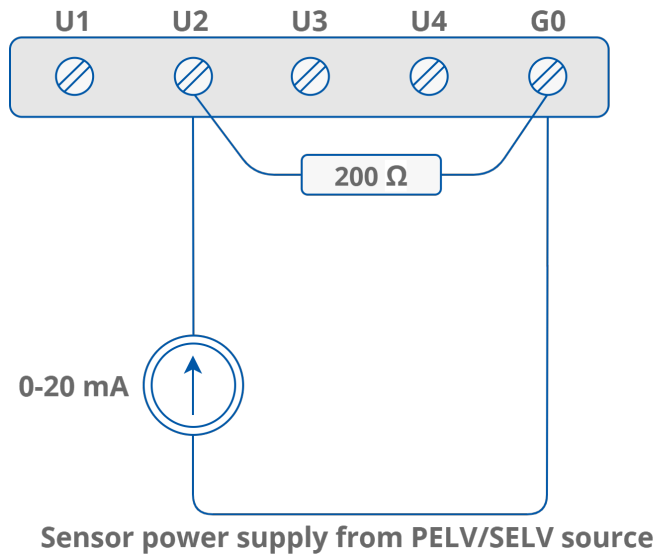

Figure 24. Universal input current connection

### 7.1.3 Universal Input Resistance Connection

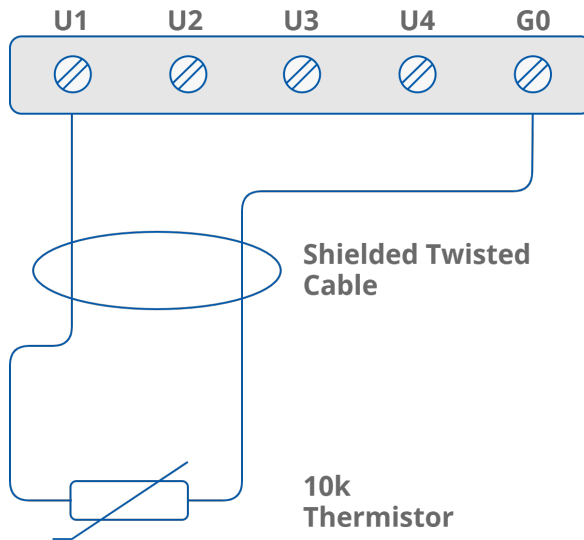

Figure 25. Universal input resistance connection

### 7.1.4 Universal Input Dry Contact Connection

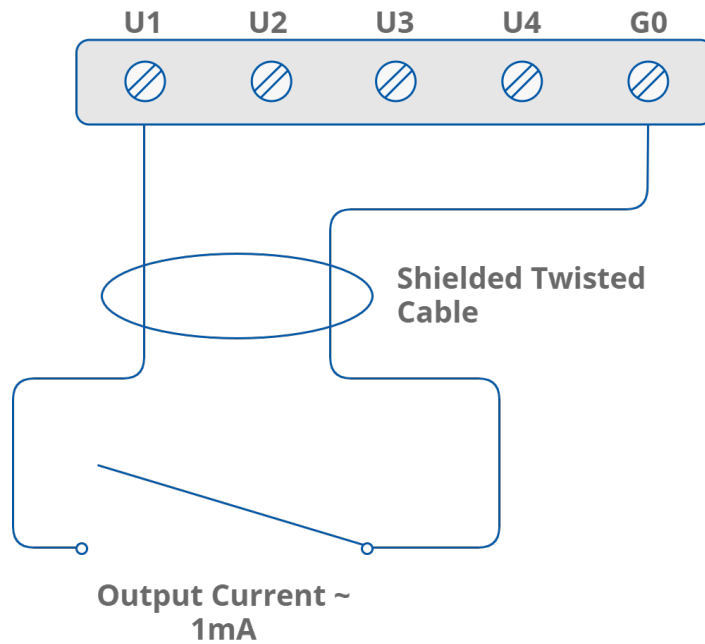

Figure 26. Universal input dry contact connection

## 7.2 Digital Inputs

The UAC28-IP device is equipped with 4 digital inputs.

Digital inputs operate as standard dry contact inputs and, additionally, as high speed pulse counters up to 100 Hz.

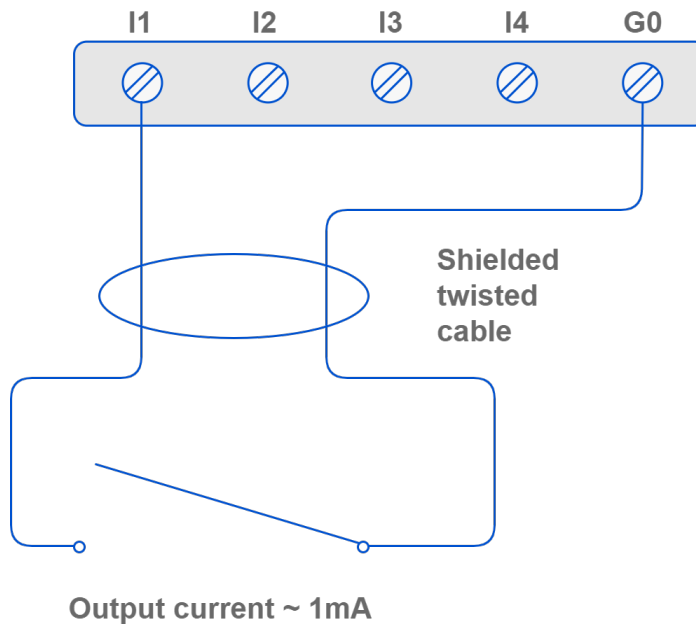

Figure 27. Digital input connection

### 7.2.1 Digital Input Counter

A digital input can work as a counter of dry contact pulses up to 100 Hz. The connection is identical as in case of the dry contact input.

## 7.3 Analog Outputs

The UAC28-IP is equipped with 6 analog outputs.

Analog outputs provide a 0-10 VDC output with maximum load up to 20 mA. They support three types of output signals:

- voltage (0-10 VDC) with maximum load up to 20 mA;
- digital;
- Pulse Width Modulation (PWM): 0.01 Hz, 0.1 Hz, 1 Hz, 10 Hz, 100 Hz.

### 7.3.1 Analog Output Voltage Connection

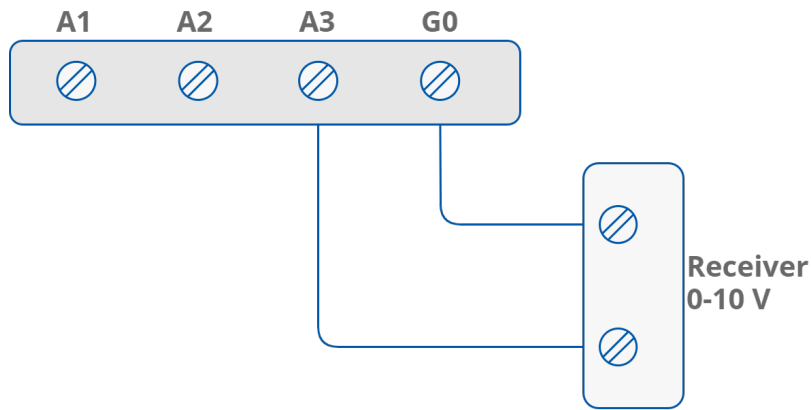

**Receiver power supply from PELV/SELV source**

*Figure 28. Analog output voltage connection*

### 7.3.2 Analog Output Relay Connection

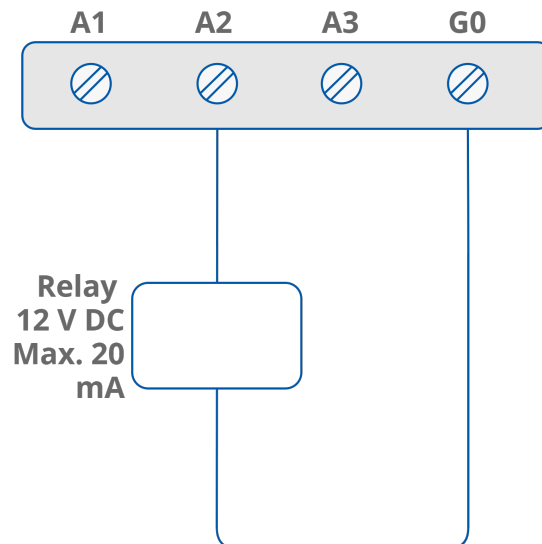

*Figure 29. Analog output relay connection*

### 7.3.3 Analog Output Actuator Connection

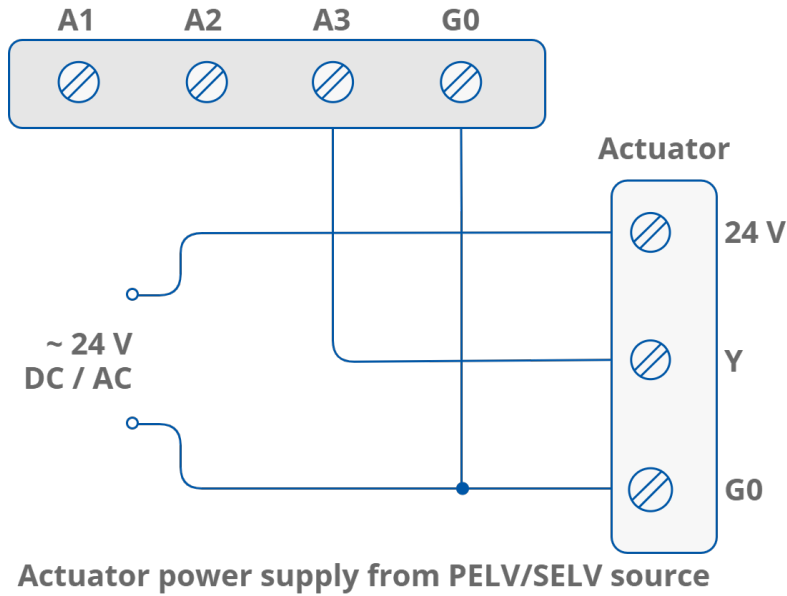

Figure 30. Analog output actuator connection

## 7.4 Digital Outputs

The UAC28-IP device is equipped with 6 digital outputs.

Digital outputs operate as relay outputs with maximum loads of:

- resistive load: 3 A at 230 V AC, and 3 A at 30 V DC;
- inductive load: 75 VA at 230 V AC and 30 W at 24 V DC.

### 7.4.1 Digital Output Electrovalve Connection

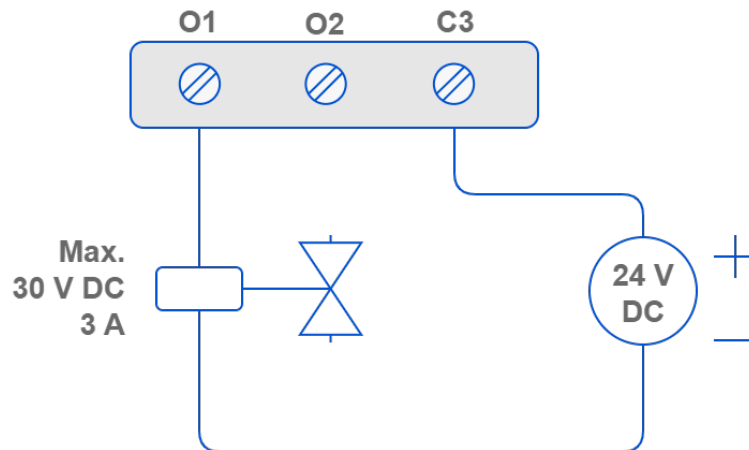

**Every OX terminal can be supplied by a different PELV/SELV source**

Figure 31. Digital output electrovalve connection

### 7.4.2 Digital Output Resistive Load Connection

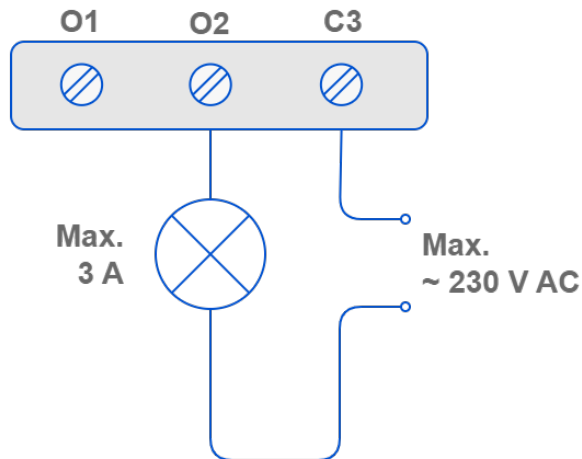

**Every OX terminal can be supplied by a different PELV/SELV source**

*Figure 32. Digital output resistive load connection*

### 7.4.3 Digital Output Inductive Load Connection

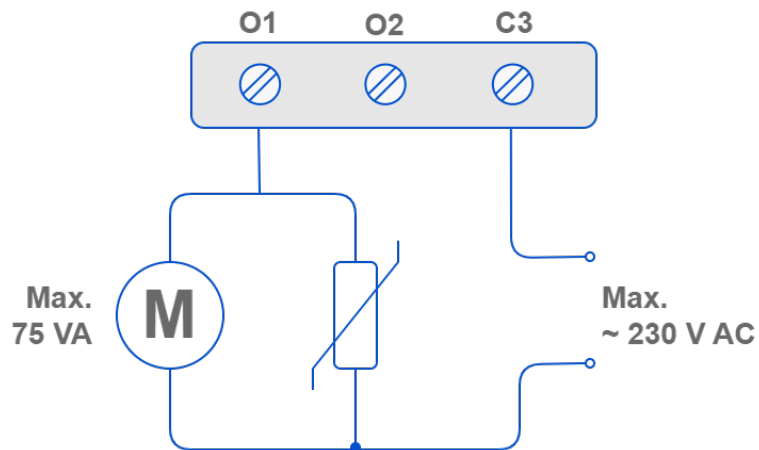

**Every OX terminal can be supplied by a different PELV/SELV source**

*Figure 33. Digital output inductive load connection*

## 8 List of Supported Temperature Sensors

- 8.0 10K3A1
- 8.0 10K4A1
- 8.0 10K Carel
- 8.0 20K6A1
- 8.0 2.2K3A1
- 8.0 3K3A1
- 8.0 30K6A1
- 8.0 SIE1
- 8.0 TAC1
- 8.0 SAT1
- 8.0 PT1000
- 8.0 NI1000
- 8.0 NI1000 21C (°C)
- 8.0 NI1000 LG (°C)
- 8.0 10K Type II NTC
- 8.0 10K Type III NTC
- 8.0 20K NTC
- 8.0 3K NTC
- 8.0 NI1000 32F (°F)
- 8.0 NI1000 70F (°F)
- 8.0 PT1000 (°F)

No.	1
Sensor	<b>10K3A1</b>
$\beta$ coefficient	3975K
Manufacturers	Aquatrol, Cylon, Honeywell, Johnson, Satchwell, Seachange
°C	$\Omega$
-50	667828
-45	491749
-40	335671
-35	241840
-30	176683
-25	131251
-20	96974
-15	72895
-10	55298
-5	42314

No.	1
0	32650
5	25396
10	19904
15	15714
20	12494
25	10000
30	8056
35	6530
40	5325
45	4367
50	3601
55	2985
60	2487
65	2082
70	1751
75	1480
80	1256
85	1070
90	916
95	787
100	678
105	587
110	510
115	444
120	388
125	340

No.	2
Sensor	<b>10K4A1</b>
$\beta$ coefficient	3695K
Manufacturers	Andover, Delta Controls, Siebe, York
°C	$\Omega$
-50	441667
-45	330749
-40	239831
-35	181532
-30	135233
-25	105081
-20	78930
-15	61030
-10	47549
-5	37316
0	29490
5	23462
10	18787
15	15136
20	12268
25	10000
30	8197
35	6754
40	5594
45	4656
50	3893

No.	2
55	3271
60	2760
65	2339
70	1990
75	1700
80	1458
85	1255
90	1084
95	939
100	817
105	713
110	624
115	547
120	482
125	426

No.	3
Sensor	<b>10K Carel</b>
$\beta$ coefficient	3435K
°C	$\Omega$
-50	329500
-45	247700
-40	188500
-35	144100
-30	111300

No.	3
-25	86430
-20	67770
-15	53410
-10	42470
-5	33900
0	27280
5	22050
10	17960
15	14690
20	12090
25	10000
30	8313
35	6940
40	5827
45	4912
50	4161
55	3536
60	3020
65	2588
70	2228
75	1924
80	1668
85	1451
90	1266
95	1108
100	973

No.	3
105	857
110	758
115	672
120	597
125	531

No.	4
Sensor	<b>20K6A1</b>
$\beta$ coefficient	4262K
$^{\circ}\text{C}$	$\Omega$
-40	806800
-35	574400
-30	413400
-25	300400
-20	220600
-15	163480
-10	122260
-5	92220
0	70140
5	53780
10	41540
15	32340
20	25340
25	20000
30	15886

No.	4
35	12698
40	10212
45	8260
50	6718
55	5494
60	4518
65	3732
70	3098
75	2586
80	2166
85	1823
90	1541
95	1308
100	1114
105	953
110	818
115	704
120	609
125	528
115	444
120	388
125	340

No.	5
Sensor	<b>2.2K3A1</b>
$\beta$ coefficient	3975K
Manufacturers	Ambiflex, Johnson
$^{\circ}\text{C}$	$\Omega$
-50	150395
-45	112994
-40	75593
-35	57691
-30	39789
-25	30814
-20	21839
-15	16416
-10	12453
-5	9529
0	7353
5	5719
10	4482
15	3539
20	2814
25	2252
30	1814
35	1471
40	1199
45	983
50	810
55	672

No.	5
60	560
65	468
70	394
75	333
80	282
85	241
90	206
95	177
100	152
105	132
110	114
115	100
120	88
125	77

No.	6
Sensor	<b>3K3A1</b>
$\beta$ coefficient	3975K
Manufacturers	Alerton
°C	$\Omega$
-50	200348
-45	150524
-40	100701
-35	76853
-30	53005

No.	6
-25	41048
-20	29092
-15	21868
-10	16589
-5	12694
0	9795
5	7619
10	5971
15	4714
20	3748
25	3000
30	2417
35	1959
40	1598
45	1310
50	1080
55	896
60	746
65	625
70	526
75	444
80	377
85	321
90	275
95	236
100	204

No.	6
105	176
110	153
115	133
120	117
125	102

No.	7
Sensor	<b>30K6A1</b>
$\beta$ coefficient	4262K
Manufacturers	Drayton
$^{\circ}\text{C}$	$\Omega$
-30	622911
-25	477393
-20	331876
-15	245785
-10	183697
-5	138502
0	105305
5	80713
10	62347
15	48511
20	38019
25	30000
30	23828
35	19046

No.	7
40	15317
45	12390
50	10079
55	8243
60	6777
65	5600
70	4650
75	3879
80	3251
85	2737
90	2313
95	1963
100	1672
105	1430
110	1228
115	1058
120	915
125	793

No.	8
Sensor	<b>SIE1</b>
Manufacturers	Barber Colman, Siebe
°C	$\Omega$
-50	10732
-45	10624

No.	8
-40	10517
-35	10344
-30	10172
-25	9913
-20	9654
-15	9320
-10	8933
-5	8496
0	8044
5	7489
10	6938
15	6370
20	5798
25	5238
30	4696
35	4185
40	3707
45	3271
50	2875
55	2521
60	2206
65	1929
70	1685
75	1472
80	1287
85	1127

No.	8
90	986
95	866
100	760
105	670
110	590
115	522
120	462
125	410

No.	9
Sensor	<b>TAC1</b>
$\beta$ coefficient	3500K
Manufacturers	TAC
°C	$\Omega$
-40	39024
-35	29358
-30	22284
-25	17073
-20	13192
-15	10276
-10	8068
-5	6382
0	5085
5	4078
10	3294

No.	9
15	2676
20	2188
25	1800
30	1488
35	1237
40	1034
45	869
50	733
55	622
60	529
65	453
70	389
75	335
80	290
85	252
90	220
95	192
100	169
105	149
110	131
115	116
120	103
125	92

No.	10
Sensor	<b>SAT1</b>
Manufacturers	Satchwell
°C	Ω
-50	9719
-45	9652
-40	9584
-35	9467
-30	9349
-25	9159
-20	8968
-15	8708
-10	8396
-5	8031
0	7614
5	7150
10	6649
15	6121
20	5580
25	5039
30	4513
35	4012
40	3545
45	3117
50	2730
55	2386
60	2082

No.	10
65	1816
70	1585
75	1385
80	1213
85	1064
90	937
95	828
100	734
105	654
110	585
115	525
120	474
125	429

No.	11
Sensor	<b>PT1000</b>
Manufacturers	Honeywell, Sauter, Serck, Siebe, Cylon
°C	$\Omega$
-50	803.1
-40	842.7
-30	882.2
-20	921.6
-10	960.9
0	1000.0
10	1039.0

No.	11
20	1077.9
30	1116.7
40	1155.4
50	1194.0
60	1232.4
70	1270.8
80	1309.0
90	1347.1
100	1385.1
110	1422.9
120	1460.7
130	1498.3
140	1535.8
150	1573.3
160	1610.5
170	1647.7
180	1684.8
190	1721.7
200	1758.6
210	1795.3
220	1831.9
230	1868.4
240	1904.7
250	1941.0
260	1977.1
270	2013.1

No.	11
280	2049.0
290	2084.8
300	2120.5
310	2156.1
320	2191.5
330	2226.8
340	2262.1
350	2297.2
360	2332.1
370	2367.0
380	2401.8
390	2436.4
400	2470.9

No.	12
Sensor	<b>NI1000</b>
Manufacturers	Sauter
°C	Ω
-50	742.6
-40	791.3
-30	841.5
-20	893.0
-10	945.8
0	1000.0
10	1055.5

No.	12
20	1112.4
30	1170.6
40	1230.1
50	1291.1
60	1353.4
70	1417.2
80	1482.5
90	1549.4
100	1617.8
110	1687.9
120	1759.8
130	1833.4
140	1909.0
150	1986.6

No.	13
Sensor	<b>NI1000 21C (°C)</b>
Manufacturers	Distech
°C	Ω
-40	699,3
-30	745,5
-20	792,8
-10	841,2
0	891,0
10	942,0

No.	13
20	994,3
30	1047,8
40	1102,6
50	1158,5
60	1215,8
70	1274,3
80	1334,4
90	1407,8
100	1473,1
110	1524,0

No.	14
Sensor	<b>NI1000 LG (°C)</b>
Manufacturers	LG
°C	Ω
-50	790,9
-40	830,8
-30	871,7
-20	913,5
-10	956,2
0	1000,0
10	1044,8
20	1090,7
30	1137,6
40	1185,7

No.	14
50	1235,0
60	1285,4
70	1337,1
80	1390,1
90	1444,4
100	1500,0
110	1557,0
120	1615,4
130	1675,2
140	1736,5
150	1799,3

No.	15
Sensor	<b>10K Type II NTC</b>
$\beta$ coefficient	3975K
Manufacturers	Alerton
$^{\circ}$ F	$\Omega$
-40	336095
-35	279921
-30	233942
-25	196184
-20	165062
-15	139324
-10	117968
-5	100192

No.	15
0	85346
5	72910
10	62464
15	53660
20	46222
25	39919
30	34563
35	30001
40	26104
45	22767
50	19903
55	17439
60	15313
65	13476
70	11884
75	10501
80	9298
85	8249
90	7333
95	6530
100	5826
105	5208
110	4663
115	4182
120	3757
125	3381

No.	15
130	3047
135	2751
140	2487
145	2252
150	2042
155	1855
160	1687
165	1536
170	1401
175	1279
180	1169
185	1070
190	981
195	901
200	827
205	761
210	701
215	646
220	597
225	551
230	510
235	472
240	438
245	406
250	377

No.	16
Sensor	<b>10K Type III NTC</b>
$\beta$ coefficient	3695K
Manufacturers	Andowver
°F	$\Omega$
-40	239831
-35	203801
-30	173631
-25	148378
-20	127139
-15	109226
-10	94078
-5	81235
0	70317
5	61012
10	53063
15	46255
20	40411
25	35382
30	31046
35	27298
40	24051
45	21234
50	18782
55	16646
60	14780
65	13148

No.	16
70	11717
75	10459
80	9353
85	8378
90	7517
95	6755
100	6080
105	5481
110	4948
115	4474
120	4051
125	3673
130	3335
135	3032
140	2761
145	2517
150	2297
155	2100
160	1921
165	1760
170	1615
175	1453
180	1363
185	1255
190	1156
195	1066

No.	16
200	985
205	910
210	842
215	780
220	723
225	671
230	623
235	580
240	540
245	503
250	469

No.	17
Sensor	<b>20K NTC</b>
$\beta$ coefficient	4262K
Manufacturers	Honeywell
$^{\circ}$ F	$\Omega$
-40	817605
-35	674624
-30	558679
-25	464299
-20	387186
-15	323956
-10	271927
-5	228972

No.	17
0	193390
5	163823
10	139177
15	118571
20	101293
25	86764
30	74511
35	64152
40	55369
45	47904
50	41543
55	36109
60	31457
65	27464
70	24029
75	21068
80	18509
85	16294
90	14372
95	12700
100	11244
105	9974
110	8862
115	7888
120	7034
125	6282

No.	17
130	5620
135	5036
140	4519
145	4062
150	3657
155	3297
160	2976
165	2691
170	2436
175	2209
180	2005
185	1823
190	1659
195	1512
200	1379
205	1260
210	1153
215	1055
220	967
225	888
230	816
235	750
240	691
245	637
250	588

No.	18
Sensor	<b>3K NTC</b>
$\beta$ coefficient	3975K
°F	$\Omega$
-40	100618
-35	83827
-30	70079
-25	58783
-20	49468
-15	41763
-10	35367
-5	30042
0	25593
5	21866
10	18735
15	16096
20	13865
25	11975
30	10369
35	9000
40	7831
45	6830
50	5971
55	5232
60	4594
65	4043
70	3565

No.	18
75	3150
80	2789
85	2475
90	2200
95	1959
100	1748
105	1562
110	1399
115	1254
120	1127
125	1014
130	914
135	825
140	746
145	676
150	613
155	556
160	506
165	461
170	420
175	384
180	351
185	321
190	294
195	270
200	248

No.	18
205	228
210	210
215	194
220	179
225	165
230	153
235	142
240	131
245	122
250	113

No.	19
Sensor	<b>NI1000 32F (°F)</b>
Manufacturers	Distech
°F	Ω
-40	791,3
-30	818,9
-20	847,1
-10	875,6
0	904,6
10	933,9
20	963,7
30	993,9
40	1024,5
50	1055,5

No.	19
60	1086,9
70	1118,7
80	1151,0
90	1183,6
100	1216,7
110	1250,2
120	1284,1
130	1318,5
140	1353,4
150	1388,5
160	1424,2
170	1460,3
180	1497,0
190	1534,1
200	1571,7
210	1609,8
220	1648,4
230	1687,9
240	1727,3
250	1767,6

No.	20
Sensor	<b>NI1000 70F (°F)</b>
Manufacturers	Distech
°F	Ω

No.	20
-40	699,3
-30	724,8
-20	750,7
-10	776,9
0	803,4
10	830,3
20	857,7
30	885,4
40	913,5
50	942,0
60	970,9
70	1000,2
80	1029,9
90	1059,9
100	1090,3
110	1121,1
120	1152,2
130	1183,8
140	1215,8
150	1248,1
160	1280,9
170	1314,2
180	1347,9
190	1382,0
200	1417,0
210	1452,0

No.	20
220	1487,0
230	1524,0
240	1560,0
250	1597,0

No.	21
Sensor	<b>PT1000 (°F)</b>
Manufacturers	Distech
°F	Ω
-40	842,7
-30	864,7
-20	886,6
-10	908,5
0	930,3
10	952,2
20	973,9
30	995,7
40	1017,4
50	1039,0
60	1060,7
70	1082,2
80	1103,8
90	1125,3
100	1146,8
110	1168,3

No.	21
120	1189,7
130	1211,1
140	1232,4
150	1253,7
160	1275,0
170	1296,2
180	1317,4
190	1338,6
200	1359,7
210	1380,8
220	1401,8
230	1422,9
240	1443,8
250	1464,8