

# UAC28-IP

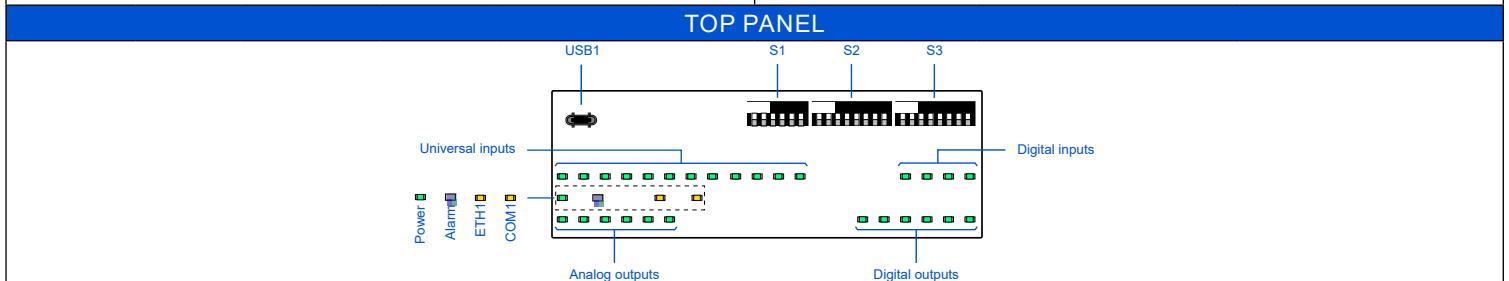

SPECIFICATION		
Power supply	DC: 24 V ± 20%, 12.3 W; AC: 24 V ± 20%, 30 VA	
Vout (COM1)	Max. 5 W, max. 40 V DC - depending on the input supply voltage 23 V DC for 24 V DC input supply voltage 33 V DC for 24 V AC input supply voltage	
Voltage output	Max. total load on Vout (COM1) and voltage output: 12 W	
Universal inputs	12 voltage, current, resistance, temperature, dry contact inputs	
Digital inputs	4, dry contact inputs, high-speed pulse counter up to 100 Hz	
Digital outputs	6 relay outputs	Max. ratings
	Resistive load (AC1)	3 A at 230 V AC, 3 A at 30 V DC
	Inductive load (AC3)	75 VA at 230 V AC
Analog outputs	6, 0-10 V DC outputs, max. load up to 20 mA per channel	
Interfaces	2x port 10/100 Ethernet switch with fail-safe protection; RS485; USB type C	
Ingress protection	IP20 - for indoor installation	
Temperature	Operating: 0°C to 50°C (32°F to 122°F) Storage: -40°C to +85°C (-40°F to +185°F)	
Relative humidity	5 to 95% RH (without condensation)	
Connectors	RS485 and I/O: separable max. 2.5 mm <sup>2</sup> (18 – 12 AWG), RS485 and Ethernet: Smart Plug (RJ45)	
Dimensions	215.5 x 109.4 x 61.7 mm (8.48 x 4.31 x 2.43 in)	
Mounting	DIN rail mounting (DIN EN 50022 norm)	
Housing material	Plastic, self-extinguishing PC/ABS	

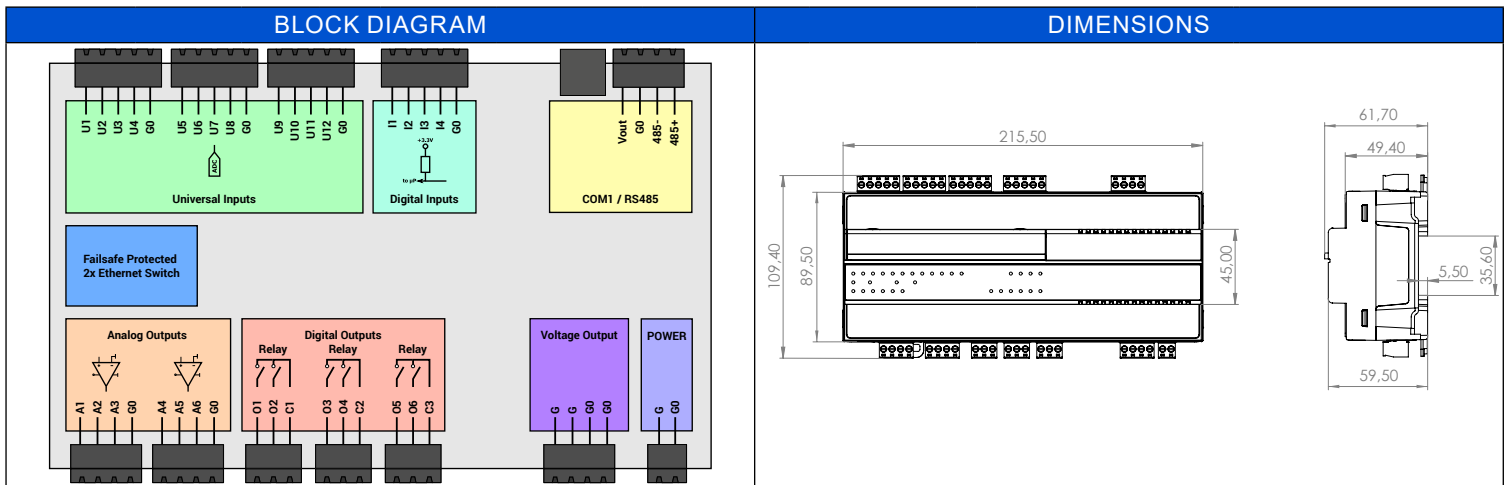

UNIVERSAL INPUTS			DIGITAL INPUTS	
<b>Voltage measurement</b>  Input impedance 100 kΩ Sensor power supply from PELV/SELV source	<b>Current measurement</b>  Sensor power supply from PELV/SELV source	<b>Temperature measurement</b>  10k Thermistor	<b>Dry contact</b>  Output current ~1 mA	<b>Dry contact</b>  Output current ~1 mA
DIGITAL OUTPUTS			VOLTAGE OUTPUT	
<b>Connection of electrovalve</b>  Max 30 V DC 3A	<b>Connection of resistive load</b>  Max 3A, Max 230 V AC Every OX terminal can be supplied by different PELV/SELV source	<b>Connection of inductive load</b>  Max 75 VA, Max 230 V AC Every OX terminal can be supplied by different PELV/SELV source	<b>POWER SUPPLY</b>  24 V AC/DC Power supply from PELV source Each G contact must be protected by external fuse if loaded	

The performances stated in this sheet can be modified without any prior notice.

## ANALOG OUTPUTS

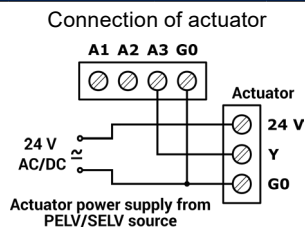
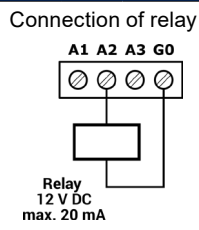
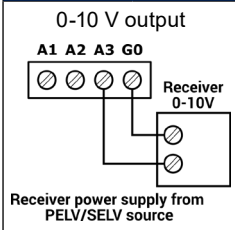

## COMMUNICATION

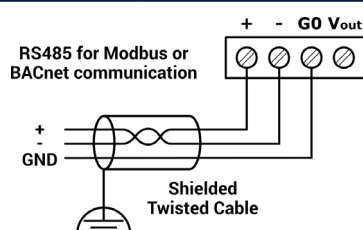

## SMART PLUG (RJ45)

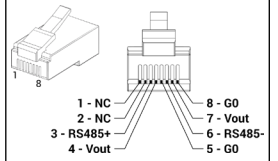

## MOUNTING ORIENTATION

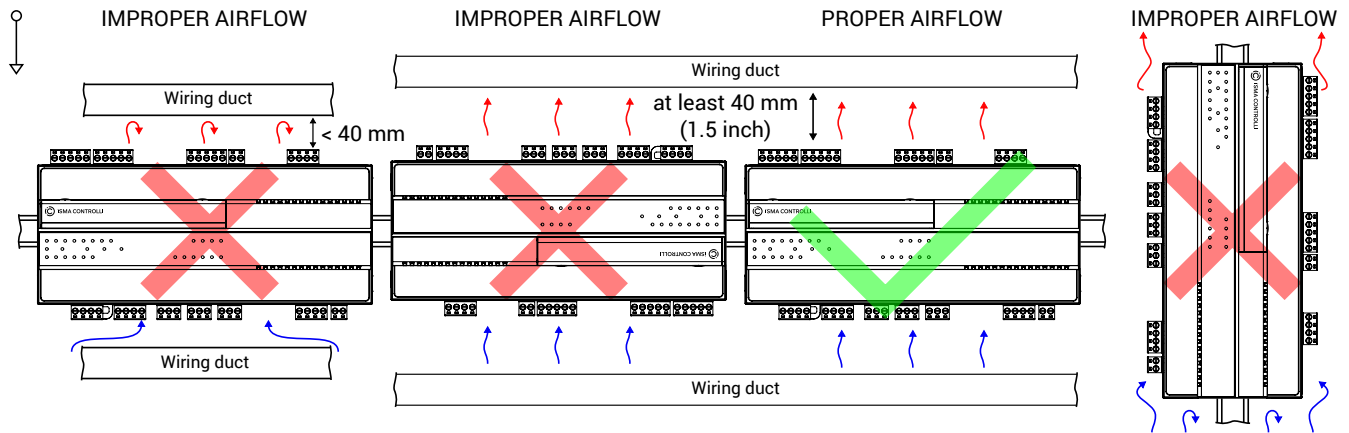

## MOUNTING - DIN RAIL

Make sure the hooks are in open position, tip of the hooks do not stick out into rail cavity in the enclosure

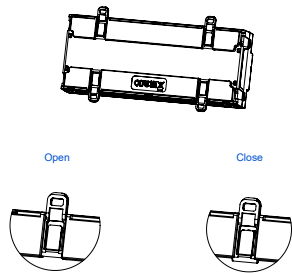

Put the controller on the DIN rail and close the hooks

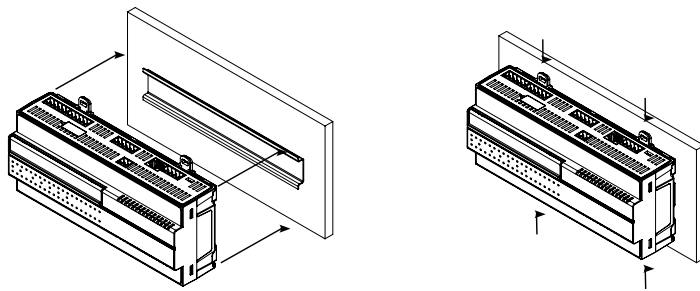

## MOUNTING - SCREWS

Set hooks into open position and put device next to the wall, use openings in hooks for marking pilot holes position.

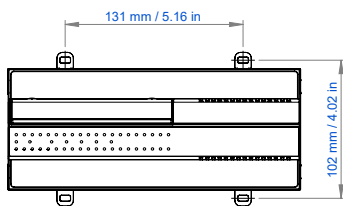

Max. screw diameter - 4.2 mm / 0.17 in

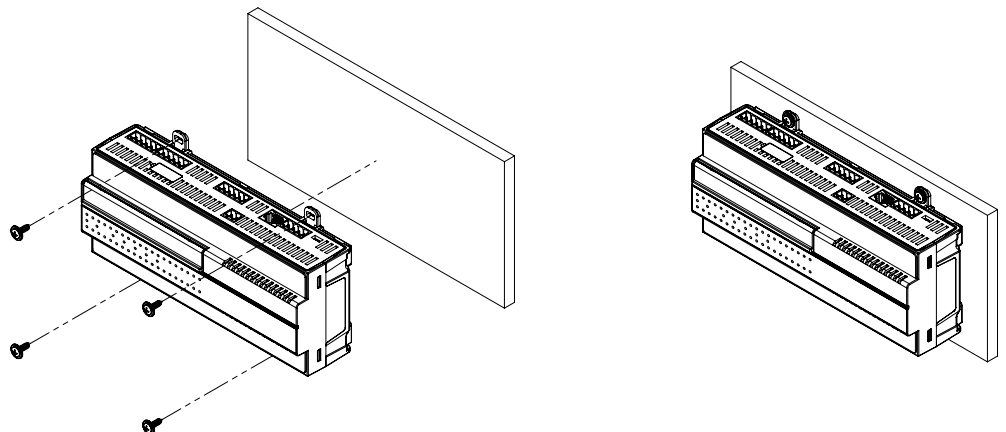

## DIP SWITCH ACCESS

To get access to USB and switches, open the blue cover on the front panel

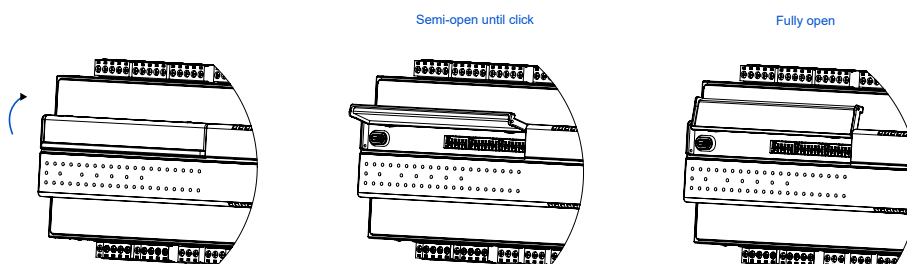

## RS485 CONFIGURATION

SWITCH POSITION	BIASING	TERMINATION 120 Ω
1 (END)	On	On
2 (BIA)	On	Off
3 (NONE) - default	Off	Off

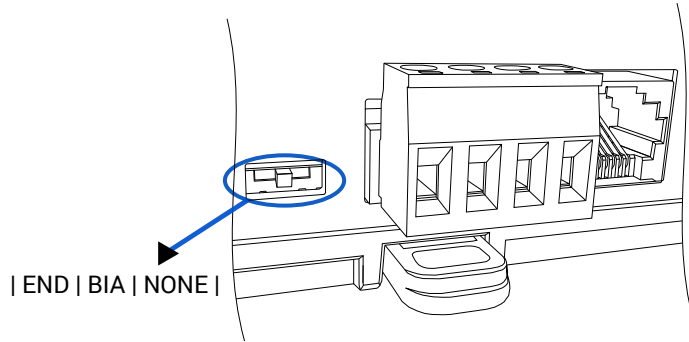

### WARNING - DEVICE INTEGRITY

Do not open device housing. Disassembly may cause damage to internal components and void warranty. Contact the manufacturer, if service is required.

Device contains no user-serviceable parts.

### FCC COMPLIANCE NOTE

**Note:** This equipment has been tested and found to comply with the limits for a Class B digital device, pursuant to part 15 of the FCC Rules. These limits are designed to provide reasonable protection against harmful interference in a residential installation. This equipment generates, uses and can radiate radio frequency energy and, if not installed and used in accordance with the instructions, may cause harmful interference to radio or television reception, which can be determined by turning the equipment off and on, the user is encouraged to try to correct the interference by one or more of the following measures:

- reorient or relocate the receiving antenna,
- increase the separation between the equipment and receiver,
- connect the equipment into an outlet on a circuit different from that to which the receiver is connected,
- consult the dealer or an experienced radio/TV technician for help.

### SAFETY COMPLIANCE NOTE

- Improper wiring of the product can damage it and lead to other hazards. Make sure that the product has been correctly wired before turning the power on.
- Before wiring or removing/mounting the product, make sure to turn the power off. Failure to do so might cause an electric shock.
- Do not touch electrically charged parts such as power terminals. Doing so might cause an electric shock.
- Do not disassemble the product. Doing so might cause an electric shock or faulty operation.
- Use the product only within the operating ranges recommended in the specification (temperature, humidity, voltage, shock, mounting direction, atmosphere, etc.). Failure to do so might cause a fire or faulty operation.
- Firmly tighten the wires to the terminal. Failure to do so might cause a fire.
- Avoid installing the product in close proximity to high-power electrical devices and cables, inductive loads, and switching devices. Proximity of such objects may cause an uncontrolled interference, resulting in an instable operation of the product.
- Proper arrangement of the power and signal cabling affects the operation of the entire control system. Avoid laying the power and signal wiring in parallel cable trays. It can cause interferences in monitored and control signals.
- It is recommended to power controllers/modules with AC/DC power suppliers. They provide better and more stable insulation for devices compared to AC/AC transformer systems, which transmit disturbances and transient phenomena like surges and bursts to devices. They also isolate products from inductive phenomena from other transformers and loads.
- Power supply systems for the product should be protected by external devices limiting overvoltage and effects of lightning discharges.
- Avoid powering the product and its controlled/monitored devices, especially high power and inductive loads, from a single power source. Powering devices from a single power source causes a risk of introducing disturbances from the loads to the control devices.
- If an AC/AC transformer is used to supply control devices, it is strongly recommended to use a maximum 100 VA Class 2 transformer to avoid unwanted inductive effects, which are dangerous for devices.
- Long monitoring and control lines may cause loops in connection with the shared power supply, causing disturbances in the operation of devices, including external communication. It is recommended to use galvanic separators.
- To protect signal and communication lines against external electromagnetic interferences, use properly grounded shielded cables and ferrite beads.
- Switching the digital output relays of large (exceeding specification) inductive loads can cause interference pulses to the electronics installed inside the product. Therefore, it is recommended to use external relays/contactors, etc. to switch such loads. The use of controllers with triac outputs also limits similar overvoltage phenomena.
- Many cases of disturbances and overvoltage in control systems are generated by switched, inductive loads supplied by alternating mains voltage (AC 120/230 V). If they do not have appropriate built-in noise reduction circuits, it is recommended to use external circuits such as snubbers, varistors, or protection diodes to limit these effects.

## INSTALLATION GUIDELINES



Please read the instruction before use or operating the device. In case of any questions after reading this document, please contact the iSMA CONTROLLI Support Team ([support@ismacontrolli.com](mailto:support@ismacontrolli.com)).



- Before wiring or removing/mounting the product, make sure to turn the power off. Failure to do so might cause an electric shock.
- Improper wiring of the product can damage it and lead to other hazards. Make sure that the product has been correctly wired before turning the power on.
- Do not touch electrically charged parts such as power terminals. Doing so might cause an electric shock.

- Do not disassemble the product. Doing so might cause an electric shock or faulty operation.



- Use the product only within the operating ranges recommended in the specification (temperature, humidity, voltage, shock, mounting direction, atmosphere, etc.). Failure to do so might cause a fire or faulty operation.
- Firmly tighten the wires to the terminal. Failure to do so might cause a fire.

- Avoid installing the product in close proximity to high-power electrical devices and cables, inductive loads, and switching devices. Proximity of such objects may cause an uncontrolled interference, resulting in an instable operation of the product.
- Proper arrangement of the power and signal cabling affects the operation of the entire control system. Avoid laying the power and signal wiring in parallel cable trays. It can cause interferences in monitored and control signals.
- It is recommended to power controllers/modules with AC/DC power suppliers. They provide better and more stable insulation for devices compared to AC/AC transformer systems, which transmit disturbances and transient phenomena like surges and bursts to devices. They also isolate products from inductive phenomena from other transformers and loads.
- Power supply systems for the product should be protected by external devices limiting overvoltage and effects of lightning discharges.
- Avoid powering the product and its controlled/monitored devices, especially high power and inductive loads, from a single power source. Powering devices from a single power source causes a risk of introducing disturbances from the loads to the control devices.
- If an AC/AC transformer is used to supply control devices, it is strongly recommended to use a maximum 100 VA Class 2 transformer to avoid unwanted inductive effects, which are dangerous for devices.
- Long monitoring and control lines may cause loops in connection with the shared power supply, causing disturbances in the operation of devices, including external communication. It is recommended to use galvanic separators.
- To protect signal and communication lines against external electromagnetic interferences, use properly grounded shielded cables and ferrite beads.
- Switching the digital output relays of large (exceeding specification) inductive loads can cause interference pulses to the electronics installed inside the product. Therefore, it is recommended to use external relays/contactors, etc. to switch such loads. The use of controllers with triac outputs also limits similar overvoltage phenomena.
- Many cases of disturbances and overvoltage in control systems are generated by switched, inductive loads supplied by alternating mains voltage (AC 120/230 V). If they do not have appropriate built-in noise reduction circuits, it is recommended to use external circuits such as snubbers, varistors, or protection diodes to limit these effects.



Electrical installation of this product must be done in accordance with national wiring codes and conform to local regulations.